



Telecommunications Infrastructure Design Standards (Version 12)

IF YOU HAVE ANY QUESTIONS OR COMMENTS ABOUT THIS INSTALLATION GUIDE PLEASE VISIT THE COMPLETE TELECOMMUNICATIONS INFRASTRUCTURE DESIGN STANDARDS ON OUR WEBSITE AT: www.fresnostate.edu/adminserv/technology/standards, OR CALL US AT 559-278-2674

Information Technology Services

Fresno CA 93740

Issuance Log

Date	Version	Description
November 26, 2012	1	Initial Release
January 4, 2013	2	Update Inner-duct Section
January 27, 2013	3	Update Documentation Section
January 31, 2013	4	Add Coaxial Station Cable Section
May 7, 2013	5	Expanded Index
September 12, 2013	6	Added Communications Legend

Issuance Log (cont)

Date	Version	Description
December 6, 2013	7	Added Contractor Qualifications
April 10, 2015	8	Added Environmental Room Specs
September 9, 2015	9	FP Updates, OSP Limits, Liquidated Damage, Testing Requirements
February 16, 2016	10	Automated Index, OSP Cable
May 10, 2017	11	Horizontal Underground Cable
July 16, 2017	12	General Housekeeping

Table of Contents

1.1	Purpose	9
1.2	Scope	9
1.3	Application	9
1.4	Qualifications of Subcontractors	10
1.5	Arrangement of Information	10
1.6	Systems Supported	10
1.7	Procedures	11
	A. Technology Services Contacts.....	11
	B. Project Design	11
	C. Project Installation	11
	D. Testing and Liquidated Damages.....	11
	1. Testing Results Completion.....	11
	2. Validation of Fiber and Copper	12
	3. Testing Failure Rates	12
	4. Repair Rates	12
	5. Liquidated Damages.....	12
	E. Scheduling	13
	F. Demolition of Existing Cabling	14
1.8	Owner-Provided Equipment	14
2.1	Telecommunication Rooms – New Construction (CSU 2.3.2).....	14
	A. Size / Critical Dimensions (EIA/TIA 569-A-8.2.2.4)	14
	B. Location and Adjacencies (EIA/TIA 569-A-7.1.2)	15
	C. Construction.....	15
	D. Door (EIA/TIA 569-A- 8.2.3.10)	15
	E. Finishes (EIA/TIA 569-A-8.2.3.7).....	16
	1. Floors.....	16
	2.	16
	3. Ceilings	16
	F. Accessibility / ADA Compliance.....	16
2.2	Telecommunication Rooms – Renovation (CSU 2.3.2)	16
	A. Sizes (EIA/TIA 569-A-Table 7.2-1)	16

- B. Critical Dimensions 17
- C. Location and Adjacencies..... 17
- D. Construction 17
- E. Door..... 17
- F. Finishes..... 17
- 3.1 New Construction (CSU 2.3.2)..... 17
 - A. Floor Loading, at Telecommunications Rooms..... 17
 - B. Seismic Bracing of Equipment Racks (FS 16710-Part 3)..... 17
 - A. Floor Loading, at Telecommunications Rooms..... 17
 - B. Floor Anchoring for Equipment Racks (FS 16710-Part3-3.1) 18
 - C. Wall Anchoring for Equipment Racks and Cabinets (FS 16710-Part3-3.1) 18
 - D. Fasteners 19
- 4.0 PLUMBING..... 19
 - 4.1 Piping Coordination through Telecommunications Rooms (EIA/TIA 569-A 8.2.5.2) 19
- 5.0 MECHANICAL..... 19
 - 5.1 Telecommunication Rooms (EIA/TIA 569-A 8.2.3.6.1)..... 19
 - A. General 19
 - B. Preferred Cooling Solutions: (CSU 3.2.1.3 Opt 1, 2, 3, 4)..... 20
 - C. Environmental Control Requirements 20
 - E. Air Changes 20
 - F. Spatial Coordination..... 20
 - G. Installation (EIA/TIA 569-A 8.2.5.2)..... 20
- 6.1 Grounding for Telecommunications/Datacom (CSU 3.2.1.2 #1) 21
 - A. Telecommunications Grounding Backbone (CSU 3.2.1.2 #2) 21
 - 1. Bonding Conductor for Telecommunications (BCT) (TIA/EIA-607)..... 21
 - 2. Telecommunications Main Grounding Busbar (TMGB) (ANSI-J-STD-607-A) 21
 - 3. Telecommunications Bonding Backbone (TBB) Conductor (TIA/EIA-607)..... 21
 - 4. Telecommunications Grounding Busbar (TGB)(ANSI-J-STD-607- A)..... 21
 - B. Telecommunications Bonding to Grounding Backbone 22
- 6.2 Electrical Service in Telecommunication Rooms 22
 - A. Convenience Outlets (TIA/EIA-569-A-8.3.2.3.10) 22
 - B. Rack Bay Service..... 22

C. UPS Service..... 22

D. Security System Service 22

E. Lighting (TIA/EIA-569-A-8.3.2.3.9) 22

6.3 Pathways Coordination (CSU 3.1.3) 22

7.1 Access Control for Telecommunication Rooms (CSU 3.2.7 #1) 23

7.2 Security Equipment, within Telecommunication Rooms (CSU 3.2.7 #2) 23

8.1 Outside Plant Underground Pathways..... 23

 A. Conduit Types 23

 B. Maintenance Hole Types (FS 16730- Part3-3.1) 23

 1. Vault-type maintenance holes/pull boxes:..... 24

 2. Split cover-type maintenance holes/pull boxes: (fs 16730-Part2-2.2) 24

 3. Hand hole-type pull boxes: (FS 16730-Part2-2.2) 24

 C. Pathway Service per Building (FS 16730-Part2-2.4) 25

 D. Installation 25

 E. Labeling 25

 F. Building Home runs 25

 G. Subduct (and Innerduct)..... 26

 H. Split Duct..... 26

 I. Splice Cases 26

8.2 Telecommunication Rooms 26

 A. Telecom Room Types..... 26

 Service Entrance and Termination Room (MDF/EF) (CSU 2.3.2.1) 26

 Equipment Room (BDF/ER) (CSU 2.3.2.2) 27

 Telecommunications Room (IDF/TR) (CSU 2.3.2.3) 27

 B. Environmental Specifications for Telecommunications Facilities..... 27

 C. Relevant Specifications Documents (Telecommunications Facilities)..... 27

 D. Equipment Specific Requirements 28

8.3 Building Pathways (CSU 2.3.3.2) 28

 A. Backbone Pathways 28

 B. Horizontal Pathways (CSU 2.3.3.3) 28

 C. Cable Tray (FS 16720-3.7) 29

 D. Primary Pathways: (FS 16720-3.7) 30

- E. Device Pathways (FS 16720-3.8) 32
- 8.4 Backbone Fiber Optic Cabling (CSU 3.3.1) 33
 - A. Cabling Deployment 33
 - 1. New Buildings..... 33
 - 2. Renovated Buildings..... 34
 - B. Outdoor Backbone Fiber Optic Cable Type (FS 16725-2.5) 34
 - C. Indoor Backbone Fiber Optic Cable Types (FS 16725-2.5)..... 35
 - D. Fiber Types..... 35
 - E. Cable Capacity / Conductor Count 35
 - 1. Campus Backbone Fiber Optic Cabling 35
 - 2. Intrabuilding Backbone Fiber Optic Cabling..... 36
 - F. Splicing (FS 16725-3.5C) 36
 - G. Termination 36
 - 1. Connectors 36
 - 2. Patch Panel..... 36
 - 3. Adapters..... 36
 - H. Backbone Fiber Optic Cabling Testing 36
- 8.5 Backbone Twisted Pair Cabling 36
 - A. OSP Backbone Twisted Pair Cable Type (FS 16725-Part 2-2.1) 36
 - B. OSP Backbone Twisted Pair Cable Capacity / Conductor Count OSP backbone..... 37
 - C. OSP Backbone Twisted Pair Cabling Entrance Termination..... 37
 - D. Indoor Backbone Twisted Pair Cable Types (CSU 4.2.2)..... 37
 - E. Indoor Backbone Twisted Pair Cable Capacity / Conductor Count (CSU 4.2.3)..... 37
 - F. Backbone Twisted Pair Cabling Termination..... 38
 - G. Backbone Twisted Pair Cabling Testing 38
- 8.6 Horizontal Cabling 38
 - A. Horizontal Cable Type..... 38
 - B. Horizontal Cables in Underground Conduit..... 39
 - C. Link Performance 39
 - D. Telecommunications Room Termination (CSU 4.2.3.1 #6) 39
 - E. Workstation Termination (CSU 4.2.3.2) 39
 - F. Modular Jacks..... 39

G. Service, Per Work Area	39
Fixed Office:	40
Open Office	40
Conference Rooms:.....	40
Classroom:.....	40
Computer Lab:.....	40
WLAN Access Point:	40
Telecom Room (TD):	40
Elevator:	40
Copy Machine:	40
BMS :	40
Fire Alarms:	40
ACAMS Panel:.....	41
8.7 Station Cabling	41
A. Copper Station Cabling	41
B. Coaxial Station Cabling.....	41
C. Coaxial Station Cable Connectors	42
8.8 Faceplate Requirements	42
A. Work Areas	42
B. Types of Faceplates.....	43
1.Basic/Wall Faceplate	43
2.Standard/Integrated Faceplate.....	43
3.Dual Faceplate.....	44
4. Data Faceplate	44
5. Wireless Access Points Faceplate.....	45
6. LCD Projector Faceplate (PTV)	45
7. Television Faceplate (TV)	46
8. Blackboard Faceplate	46
9. Fire Alarm Faceplate	47
10. Camera Faceplate.....	47
11. Energy Management Systems Faceplate (EMS).....	48
12. Power Meter Faceplate.....	48

C. Station Outlet Requirements	49
D.Faceplate Designations.....	50
E.Work Area Design Considerations	50
Administrative Work Areas	50
A minimum of two Standard Faceplates is provided in each office. The telecommunications outlets should be located to offer maximum flexibility for change in the work area, i.e., on opposing walls.	50
Conference Rooms.....	50
Large Classrooms (over 50 occupants)	50
Small Classrooms	50
Public Areas.....	51
Laboratories	51
Special Use Telecommunication Modules	51
8.9 Administration / Labeling.....	51
General.....	51
Identifier Assignment.....	51
Horizontal Cables	51
Backbone Cables	51
Patch Panel Labeling	52
Outlet Labeling.....	52
8.10 Documentation	52
8.11 Construction Trailer Equipment.....	53
9.0 WIRELESS LAN SERVICE	54
See Technology Services for information	54
10.0 INSTRUCTIONAL TECHNOLOGIES (CVS)	54
See Technology Services for information	54
INDEX on Next Page	54
APPROVED MATERIALS LIST	56
ADDENDUM 2.	57
TELECOMMUNICATIONS LEGEND.....	57

1.0 INTRODUCTION

1.1 Purpose

This purpose of this document is to describe minimum requirements and establish design guidelines for telecommunications / datacom infrastructure that will support information systems and other data-based systems. This document describes requirements and criteria to guide the Design Team (datacom, electrical, mechanical, and other disciplines) and the Contractor to provide the minimum infrastructure and support for information systems.

This document is not intended to be used as project specifications. Rather, each project shall have produced technical specifications. Also refer to the Fresno State website.

1.2 Scope

The scope of this document includes the following:

- Architectural, Structural, Electrical, Mechanical, Plumbing, and Security requirements for Telecommunications Rooms build-out/fit-up
- Outside Plant Underground Pathways
- Telecommunications Rooms build-out/fit-up, including equipment and termination apparatus racking and cable support
- Building Pathways
- Backbone Cabling
- Horizontal Cabling
- Faceplate Requirements
- Construction Trailer Rates
- Wireless LAN Deployment
- Instructional Technologies

NOTE: Every attempt has been made to provide supporting documentation and reference material associated with the sections included in this standard. Documentation was taken from the following sources in the following order:

Primary Reference Source:	Fresno State TID Standard.... (FS)
Secondary Reference Source	CSU System TIP Standard.... (CSU)
Tertiary Reference Source	BICSI Standards..... (BICSI)
Quaternary Reference Source	EIA/TIA/BICSI Standards..... (EIA/TIA)

1.3 Application

Information technologies are a critical element in the design of virtually all new and renovation building projects. Whether voice, data, video, security, fire alarm systems, audio/visual systems, or other technology, it is important that a team of experienced professionals are involved in the design of these complex systems. The requirements and criteria herein apply to the Fresno State Campus. A Structured Cabling Plant is a key concept in enabling Information Technology. To maximize network functionality, minimize labor and material costs, and improve maintenance of information technologies infrastructure, Technology Services has developed standards and practices that projects shall comply to. These standards are managed and administered by the Technology Services Department.

1.4 Qualifications of Subcontractors

- All Information Transports Systems (ITS) Contractor or Subcontractors employed by the Contractor shall have a minimum of 5 years' experience in satisfactory completion of jobs of similar scope and amount.
- The Contractor shall provide upon request, detailed information relating to similar work completed by all ITS Contractor or Subcontractors employed for this project, including corporate references, to enable the University to evaluate and agree to the Contractor's or Subcontractors' responsibility, experience, and capacity to perform the stated work.
- Each ITS Contractor or Subcontractor employed to perform telecommunications work on this project shall possess a C-7 (formerly C-61) Limited Specialty License for Telecommunications and must be certified to install, terminate, splice, and test copper cables, fiber optic cable, riser cable, and inside wiring. This requirement ensures integration into, support, maintenance, and warrantee by the Contractor of the University's new and applicable existing telecommunications infrastructure. The appropriate Contractor or Subcontractor's license for underground construction and conduit installation is also required when applicable.
- The ITS Contractor, whether sub-contracted to the General Contractor or to the Electrical Contractor shall have one on-site employee assigned to the project that is BICSI RCDD or BICSI Technician certified.
- Technicians installing and terminating telecommunications cables will be Leviton Certified. Certification verification shall be submitted with materials submission prior to contract award.
- The installing Contractor or Subcontractor of the Structured Cabling System must be a certified installer, able to provide the chosen materials manufacture 25 year applications warranty.
- An on-site ITS Contractor superintendent must be available at all times. Contact can be by person, telephone, or email.

1.5 Arrangement of Information

This document is arranged by design discipline. Best practice has the Designer reading the entire document and related documents; however, the Designer may study the specific sections related to their discipline, and review the other sections.

Note: There is a list of Fresno State approved materials at the end of this document (Addendum)

1.6 Systems Supported

The telecommunications infrastructure shall support data network communications from the equipment in the Telecommunications Room (e.g., switch) to the work area equipment (e.g., desktop computer) and between equipment in Telecommunications Rooms (e.g., core switch in MDF to access switch in BDF or IDFs).

The data network will support, at a minimum, IP-based host-client applications and voice-over-IP (VoIP) applications.

The telecommunications infrastructure shall support telephone communications from the equipment in the Telecommunications Room to the work area and between Telecommunications Rooms. Examples of these applications include analog non-VoIP voice services to devices such as elevator, E-phones, EMS, Cameras, and alarm panels.

The telecommunications infrastructure shall support additional building systems such as security systems, building control systems, fire alarm, . . etc.

1.7 Procedures

A. Technology Services Contacts

Use the following URL for TECHNOLOGY SERVICES contact information:

fresnostate.edu/adminserv/technology/standards

B. Project Design

Projects designed and led by an architect/engineer, whether a capital project, shall have the telecommunications infrastructure designed by a Telecom Designer (part of the Design Team or associated consultant) **approved by Technology Services.**

This infrastructure shall include all pathways, cabling, terminations, testing and telecom room construction related to the telecommunications systems. The Designer shall provide services in accordance with these standards, **and as directed Technology Services** The Design Team shall verify that all applicable portions of these standards are incorporated into the project's design, drawings, specifications and final construction. Requests for variances from these standards shall be submitted in writing to the Technology Services Project Manager.

C. Project Installation

The Contractor shall be fully capable of providing an extended system warranty, and shall be experienced in this structured cabling system.

This infrastructure shall include all pathways, cabling, terminations, testing and telecom room construction related to the telecommunications and AV systems. The Designer shall provide services in accordance with these standards, and as directed by Technology Services.

The Design Team shall verify that all applicable portions of these standards are incorporated into the project's design, drawings, specifications and final construction. Requests for variances from these standards shall be submitted in writing to the Technology Services Project Manager.

D. Testing and Liquidated Damages

1. Testing Results Completion

A mutually agreed upon testing results completion deadline between the Contractor/Vendor and Fresno State's Technology Services will be established at the time of the generation of the Purchase Order or the awarding of the bid. This date will be at least two weeks (10 working days) prior to the turning over of the building for occupancy. This allows Technology Services time to validate the test results and insure that all testing is complete prior to placing copper and fiber into service. All copper horizontal station cable and fiber optic cable testing will

comply with (TIA) ANSI/TIA/EIA-568-B.1 or (ISO) ISO/IEC 11801 Ed.2 Industry Standards, and be done using a current, certified and calibrated Fluke test instrument. Copper tie-cables and OSP underground cable only need to be tested for length, opens, shorts, grounds, and crosses. Copper horizontal station cables and fiber optic cables test results will be delivered to Technology Services in the Fluke LinkWare format digitally. Tie-cable and OSP underground cable test results will be delivered to Technology Services on a Microsoft Spreadsheet in digital form.

2. Validation of Fiber and Copper

Technology Services will conduct tests on ten (10%) percent of the accepted OSP copper and tie-cables on a random basis, if more than one (1%) percent indicate trouble then a second ten (10%) percent will be randomly tested, for any failures found over one (1%), the Contractor/Vendor will be required to repair and retest them.

Fiber Optic Cables and Horizontal Station Cables will also be randomly tested to validate test results. The failure rate for these is zero (0%) percent. Technology Services will conduct tests on ten (10%) percent of the fiber and station cable if there are any failures then a second ten (10%) percent will be randomly tested. For any failures that need to be repaired, Technology Services has the option of doing the repairs and recertification themselves, or having the Contractor/Vendor do the repairs and recertification, or by using a third party to recertify and repair the cables in question. Any additional labor costs to repair and recertify will be done at the expense of the Contractor/Vendor.

3. Testing Failure Rates

Tie-cables and OSP underground cables can have up to a one (1%) percent failure rate, if properly documented. The most common problem with horizontal station cable is split pairs, if tested properly, these can be identified very easily. Horizontal copper station cables and fiber optic cables will have zero (0%) percent failures. If the contractor's test results cannot be validated or are inaccurate or some cables need to be repaired, Technology Services has the option of doing the repairs and recertification themselves, or having the Contractor/Vendor do the repairs and recertification, or by using a third party to repair and recertify the cables in question. Any additional labor costs to repair and recertify will be done at the expense of the Contractor/Vendor.

4. Repair Rates

The cost of the initial random testing of copper and fiber will be borne by Technology Services as part of the cost of doing business. Any additional repair and testing charges incurred by Technology Services or a third party vendor will be done at the expense of the Contractor/Vendor at our current non-state hourly rate. The cost will be the current "time and material" rate of Technology Services for non-state agencies as determined by the Chancellor's Office.

5. Liquidated Damages

(7.02) Delay in Completion - Liquidated Damages (Contract General Conditions)

If the Work is not completed within the time required, damage will be sustained by the

University. It is, and will be, impractical and extremely difficult to determine the actual damage that the University will sustain by reason of the delay. It is therefore agreed that the Contractor will pay to the University the sum of money stipulated per Day in the Contract for each Day's delay in completing the Work beyond the time prescribed, see Article 8.01, Acceptance. If the Contractor fails to pay such liquidated damages, the University may deduct the amount thereof from any money due or that may become due the Contractor under the Contract (Public Contract Code section 10826). If the University has occupancy of all or a portion of the Project, the University may reduce the amount of assessment of liquidated damages, if it is determined to be in the best interest of the University. The University's assessment of liquidated damages shall not commence on a Saturday, Sunday or legal holiday.

(8.01) Acceptance (Contract General Conditions)

When the whole project has been completed in all respects in accordance with the plans and specifications, to the full satisfaction of the University, a Notice of Completion will then be filed by the University with the County Recorder in the county in which the project is located. Projects bid with a segregation of costs for separate, independent portions may, at the University's discretion, have each of the separate portions accepted individually. The date of recording on the Notice of Completion shall be the official completion date relating to claims and stop notices. All stop notices must be filed with the University within 30 calendar days after the County Recorder's recordation date on the University's timely Notice of Completion. All claims arising from this contract shall be submitted in writing to the University no later than 30 calendar days after the recordation date on the University.

NOTE: In order for Liquidated Damages to be enforced Technology Services must include one of the two options listed below in the contract or Purchase Requisition:

(A) CONTRACT CLAUSE: (Must be included in a contract)

The Contractor shall fully complete all the Work of the Contract, in first class working order and ready for acceptance by the Trustees, on or before the expiration of <insert #> calendar days from the starting time so fixed. The Contractor will pay to the Trustees the sum of Five Hundred Dollars (\$500.00) for each day completion is delayed beyond the time prescribed, in accordance with the Contract General Conditions, Article 7.02, Delay in Completion—Liquidated Damages.

(B) PURCHASE REQUISITION CLAUSE: (Must be included in a Purchase Requisition:

For projects that are subject to critical deadlines and LD's, simply include on your requisition: Start Date, End Date and Amount of LD's for each day work is not complete beyond the end date.

E. Scheduling

Designers and Contractors shall develop construction schedules that allow adequate time for Technology Services to inspect the installation and perform equipment provisioning, as stated following, prior to the Owner's occupancy of each part of a project. Technology Services will provide intervals to the Contractor for inclusion in overall project schedule.

Contractors shall to cooperate with Technology Services personnel and allow them equal access to the jobsite to complete their work, concurrent with other work underway by the Contractor.

F. Demolition of Existing Cabling

If existing cabling must be demolished, coordinate with Technology Services the extent of the demolition work. Technology Services may choose to have some equipment recovered (such as jacks, faceplates, racks, or other components), or cables saved for future use. The demolition plans must be produced with this information expressly stating the components to be recovered and turned over to Technology Services.

1.8 Owner-Provided Equipment

Technology Services will furnish and install the networking equipment, telephone handsets, and AV equipment as required. Technology Services shall perform the final patching between the networking equipment and horizontal field and the final cross-connect wiring between the backbone field and horizontal field.

2.0 ARCHITECTURAL

2.1 Telecommunication Rooms – New Construction (CSU 2.3.2)

Refer to section 8.2 for descriptions of the different types and functions of the Telecommunications Rooms. “Telecommunications Room” covers service entrance room, main distribution room, and intermediate distribution room.

A. Size / Critical Dimensions (EIA/TIA 569-A-8.2.2.4)

Use the following dimensions as guidelines for the minimum size of a Telecommunications Room. The actual dimensions will vary depending upon attaining the minimum critical dimensions and accommodating building elements. These are the minimum critical dimensions for equipment and clearances for rooms to house floor-standing equipment racks:

1. Width: 10'-0"
2. Depth: 7'-0" for the first rack and UPS, 30" for each additional rack (recommend three racks for typical floor plate of approximately 50,000 square-feet). See diagram below for example.
3. Height: 9'-6" from finished floor to the lowest clearance (such as fireproofing on steel beam).

If area is encroached by building elements such as columns, critical dimensions must still be adhered to and the room dimensions appropriately adjusted.

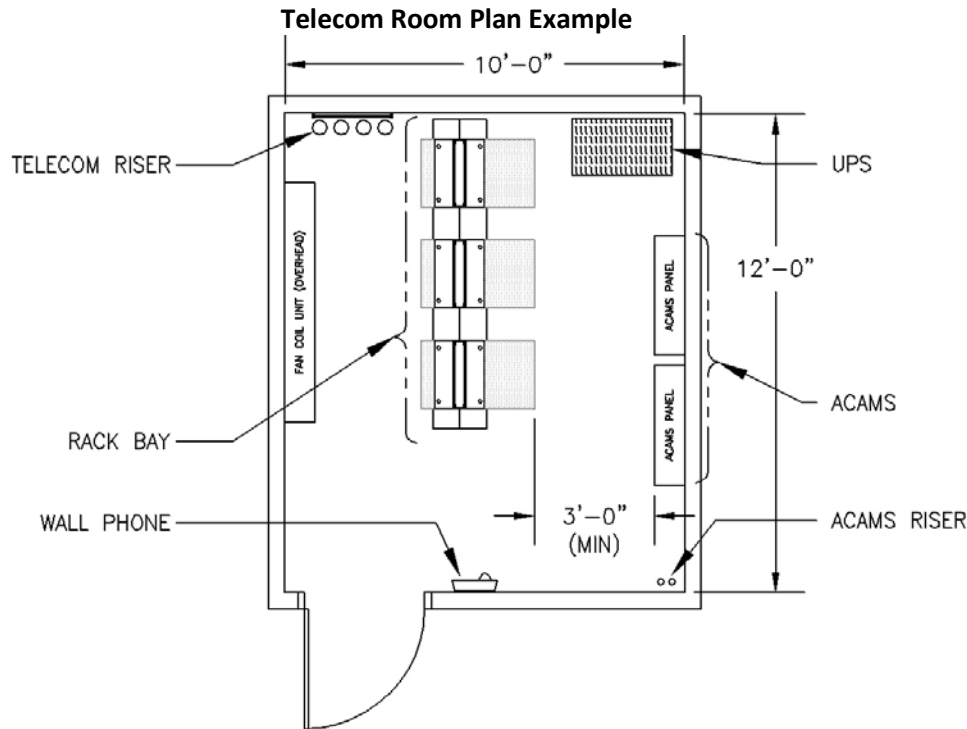

B. Location and Adjacencies (EIA/TIA 569-A-7.1.2)

Telecommunications Rooms should be centrally located on the floor plate. Telecommunications Rooms should be located such that there are no areas of telecom service beyond a circle area with a diameter of approximately 165 feet centered in the Telecommunications Room. In other words, every telecom outlet should fall within that 165' radius circle.

In multi-story Buildings, Telecommunications Rooms should be vertically, adjacent / stacked floor-to-floor. This will improve long-term management and will result in lower construction costs for backbone pathways and backbone cabling.

C. Construction

Walls should be typical metal-stud framed walls. However, wall construction will depend on building design.

Walls are not required to be fire rated.

Walls

shall be full height – to the structure above.

D. Door (EIA/TIA 569-A- 8.2.3.10)

Swing: The door should swing outward to maximize the usable area within the room, though egress codes may dictate an inward swing (for example, if the Telecommunications Room were to be located on a main egress corridor). If the door swings into the room, the door shall swing into the clearance space.

Size: The door shall be 36" wide by 84" tall, minimum.

E. Finishes (EIA/TIA 569-A-8.2.3.7)

1. Floors

Floors shall be either sealed concrete or the same resilient floor product that is being installed in the contiguous public floor areas.

2.

Concrete and/or CMU walls shall be sealed prior to receiving plywood backboard.

Walls shall receive one layer of 1 inch plywood as backboard. The plywood shall be fire treated, in accordance with ASTM E-84. The plywood shall be installed starting at 6-inches above the floor up to 8'-6", minimum. The fasteners shall be designed per instance, and will depend on the substrate (wall type) and project requirements. The suggested installation shall be five equally-spaced fasteners installed vertically on both sides and in the middle of each plywood sheet. For framed walls, install the fasteners into the studs and/or preinstalled backing plate.

The plywood shall be painted a bright color (such as white, to improve lighting/illumination) with two coats of a semi-gloss paint. **Mask fire rating stamp prior to painting.**

3. Ceilings

The ceilings shall be left open. That is, no ceiling is required.

F. Accessibility / ADA Compliance

Though building codes may vary as well as the enforcement of those codes, Telecommunications Rooms contain equipment non-compliant to ADA accessibility requirements. For example, the equipment racks will contain equipment at about 90" that needs to be accessed.

That said, this document loosely recommends that no ADA accessibility design aspects be applied to Telecommunications Rooms unless required by code.

2.2 Telecommunication Rooms – Renovation (CSU 2.3.2)

For the most part, renovation projects shall come as close to new construction requirements as possible. While acknowledging that Telecommunications Rooms often get "shoe-horned" into a space on the floor plan (usually a space that can't be used for anything else), the lack of plentiful space for Telecommunications Rooms does not lessen the clearance requirements or make the equipment smaller.

A. Sizes (EIA/TIA 569-A-Table 7.2-1)

The size of the room may or may not be confined by existing conditions.

If the size is not confined by existing walls, then refer to "Telecommunication Rooms – New Construction" \ "Sizes" previously. The same sizing guidelines apply to renovation as well.

B. Critical Dimensions

Refer to “Telecommunication Rooms – New Construction” previously. The same critical dimensions apply to renovation as well.

C. Location and Adjacencies

Where possible, Telecommunications Rooms should be centrally located on the floor plate and should be vertically adjacent / stacked.

D. Construction

Where new walls are constructed, walls should be typical metal-stud framed walls. Walls shall be full height – to the structure above.

E. Door

Refer to “Telecommunication Rooms – New Construction” previously. The same door requirements apply to renovation as well.

F. Finishes

Refer to “Telecommunication Rooms – New Construction” previously. The same finishes requirements apply to renovation as well.

3.0 STRUCTURAL

3.1 New Construction (CSU 2.3.2)

A. Floor Loading, at Telecommunications Rooms

Floor loading at Telecommunications Rooms shall be 100 pounds per square-foot, minimum.

B. Seismic Bracing of Equipment Racks (FS 16710-Part 3)

In Telecommunications Rooms Equipment racks, possibly both floor-mounted and wall-mounted, will be installed into Telecommunications Rooms.

For design-bid-build projects, the Design Team’s Structural Engineer shall be responsible to confirm the seismic bracing design (including structural calculations and details as required by the Project), and shall provide recommendations as necessary.

For design-build projects, the Construction Team’s Structural Engineer shall be responsible to design the seismic bracing for the equipment racks.3.2 Renovation Construction (CSU 2.3.2)

A. Floor Loading, at Telecommunications Rooms

The floor load capacity will be dependent upon existing conditions. The floor loading should be 100 pounds per square-foot, minimum. If the Structural Engineer has determined the floor system has a

capacity lower than this requirement, then the Structural Engineer must notify Technology Services (either directly or through the Design Team lead).

B. Floor Anchoring for Equipment Racks (FS 16710-Part3-3.1)

Floor-standing equipment racks and cabinets shall be anchored to the structural floor via devices pre-approved by DSA(Distribution Systems Architecture). Examples of such devices include Hilti Kwik-Bolt 3. The structural engineer shall determine the applicability of the anchoring device set in the floor system, including minimum embedment depth.

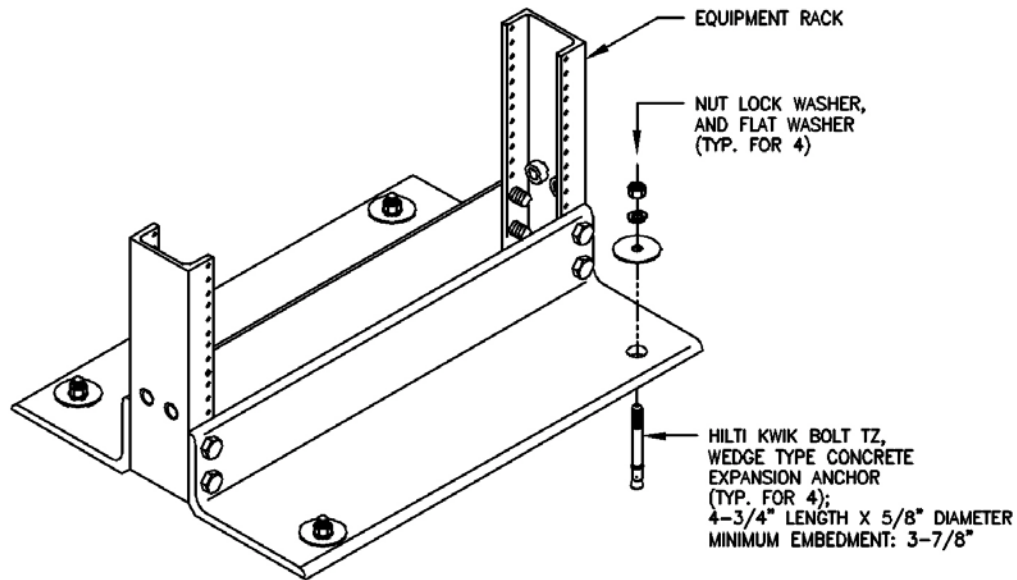

C. Wall Anchoring for Equipment Racks and Cabinets (FS 16710-Part3-3.1)

Wall-mounted equipment racks and cabinets shall be anchored to the wall via fasteners pre-approved by DSA. Examples of such fasteners include woods screws into plywood backboard and expansion anchors into concrete wall. The structural engineer shall determine the applicability of the fasteners depending upon the mounting substrate, including minimum embedment depth.

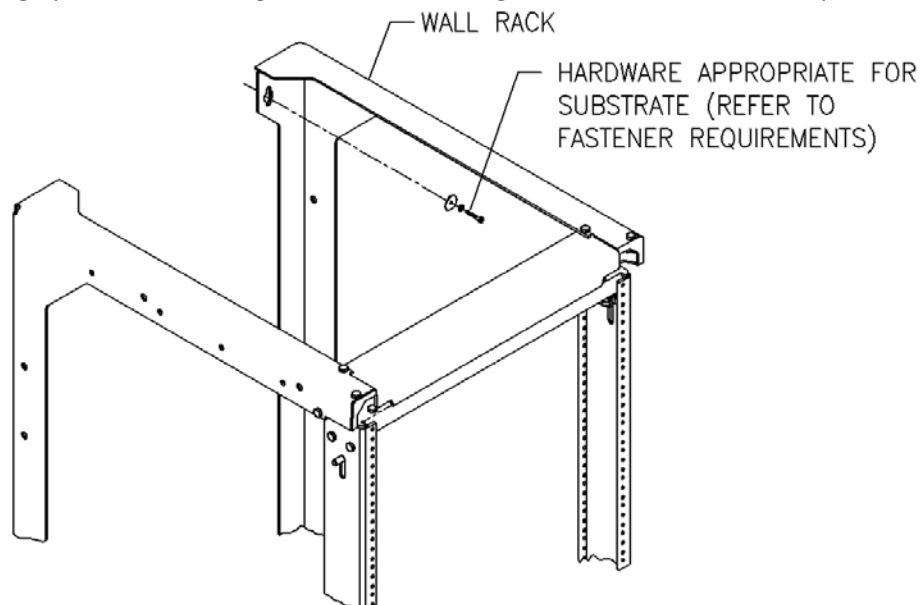

Wall Rack Mount Example

D. Fasteners

The following chart is a guide to the fasteners generally approved for mounting backboards, equipment, etc.

Wall Type	Fastener Required
Concrete Wall	TAPCON, 3/16" x 1¼" with 1" min embedment
CMU Wall	TAPCON, 3/16" x 1¼" with 1" min embedment
Metal Stud Framed Wall, 1 Layer Gypsum	Into metal stud: no. 8 x 2" self-tapping metal screw for metal studs
	Into gypsum wallboard: Toggler toggle bolt BA (3/16" x 24)
Wood Stud Framed Wall, 1 layer Drywall	Into wood stud: no. 8 x 2" wood screw
	Into gypsum wallboard: Toggler toggle bolt BA (3/16" x 24)
Plaster Wall	Toggler toggle bolt BA (3/16" x 24)
Plywood Backboard	no. 8 x 2" wood screw

4.0 PLUMBING

4.1 Piping Coordination through Telecommunications Rooms (EIA/TIA 569-A 8.2.5.2)

Piping and plumbing unrelated to telecom (other than what is required to support the room such as chilled water supply/return) shall not be routed through Telecommunications Rooms and/or on the floor above and directly over Telecommunications Rooms.

If any piping must be routed through a Telecommunications Room, the design must be carefully coordinated with the Design Team lead, the Telecom Engineer, and Technology Services. This will involve alternate designs to the room and containment design for the piping. The Plumbing Engineer shall obtain acceptance in writing by Technology Services and District to route piping through a Telecommunications Room.

5.0 MECHANICAL

5.1 Telecommunication Rooms (EIA/TIA 569-A 8.2.3.6.1)

A. General

In general, each Telecommunications Room will require environmental control. The design for environmental control per instance will depend on the rooms' heat load and the building's infrastructure. There may be instances where the load is low enough to allow simple ventilation to cool the room while most instances will require a dedicated system. Each room's cooling design must be accepted in writing by Technology Services.

B. Preferred Cooling Solutions: (CSU 3.2.1.3 Opt 1, 2, 3, 4)

If the building has a chilled water loop, the preferred solution is a fan coil unit connected to the chilled water loop. If the building does not have a chilled water loop, the preferred solution is a dedicated split system. If the rooms' heat load is low enough (under 1,500–2,000 BTU/hour) and the building does not have a chilled water loop and the Building has general air conditioning, the room could be cooled via ventilation (air changes). Though a dedicated cooling system is preferred, project budgets must be considered.

C. Environmental Control Requirements

Mechanical equipment within Telecommunications Rooms shall be controlled and monitored by Fresno State's Building Management System.

The temperature in Telecommunications Rooms shall be controlled between 65 and 85 degrees Fahrenheit.

D. Loads

The load will be determined per instance. The recommended load, in lieu of no specific criteria, is 40 watts per square foot. The Mechanical Engineer can assume 12,000 BTU/hour per room or applying a 1-ton unit.

The temperature in Telecommunications Rooms shall be maintained between 65 and 85 degrees Fahrenheit, and shall cause a system alarm on the BMS (Building Management Systems) when it goes outside of those parameters.

E. Air Changes

Telecommunications Rooms require one air change per hour, minimum.

F. Spatial Coordination

The Telecommunications Rooms' equipment layout will be based on a standardized design approach. The mechanical design and mechanical equipment layout shall follow the telecom/datacom equipment layout. In general, locate the cooling unit in front of the rack bay. The Mechanical Engineer shall be responsible for coordination of the final locations of mechanical systems and equipment with the Telecom Engineer and Technology Services, as well as through the Design Team.

G. Installation (EIA/TIA 569-A 8.2.5.2)

The cooling unit (for example, fan coil unit) shall be installed either hung from the structure above or high on the wall. Coordinate the location of the condensate pump to avoid conflict with telecommunications/datacom equipment.

The location of the cooling unit shall be coordinated with the equipment plan as not to have wet components above the equipment racks or other equipment that could be damaged by leaks. The piping to the cooling unit shall be routed as not to pass over the rack bay and the equipment clearance of the rack bay. Piping connections shall not be installed over where equipment may be installed.

Ducting unrelated to the Telecommunications Room shall not be routed through Telecommunications Rooms.

6.0 ELECTRICAL

6.1 Grounding for Telecommunications/Datacom (CSU 3.2.1.2 #1)

A. Telecommunications Grounding Backbone (CSU 3.2.1.2 #2)

A grounding backbone is required for each building with a ground terminal presented in each Telecommunications Room.

The Telecommunications Grounding Backbone shall be designed in compliance with ANSI-J-STD-607-A.

1. Bonding Conductor for Telecommunications (BCT) (TIA/EIA-607)

A BCT is required from the TMGB to the main building ground reference. The conductor shall be insulated, green. Size the conductor as 1,000 circular-mils per foot up to 3/0 AWG.

2. Telecommunications Main Grounding Busbar (TMGB) (ANSI-J-STD-607-A)

A TMGB is required in the MPOE/MDF/BDF/IDF. Refer to ANSI-J-STD-607-A for busbar size and requirements. The Electrical Designer shall coordinate the busbar location with Technology Services (location will depend on equipment layout).

3. Telecommunications Bonding Backbone (TBB) Conductor (TIA/EIA-607)

A TBB is required from the TMGB to each TGB. The conductor shall be insulated, green. Size the conductor as 1,000 circular-mils per foot up to 3/0 AWG.

4. Telecommunications Grounding Busbar (TGB) (ANSI-J-STD-607-A)

A TGB is required in the MPOE/MDF/BDF/IDF. Refer to ANSI-J-STD-607-A for busbar size and requirements. The Electrical Designer shall coordinate the busbar location with Technology Services (location will depend on equipment layout).

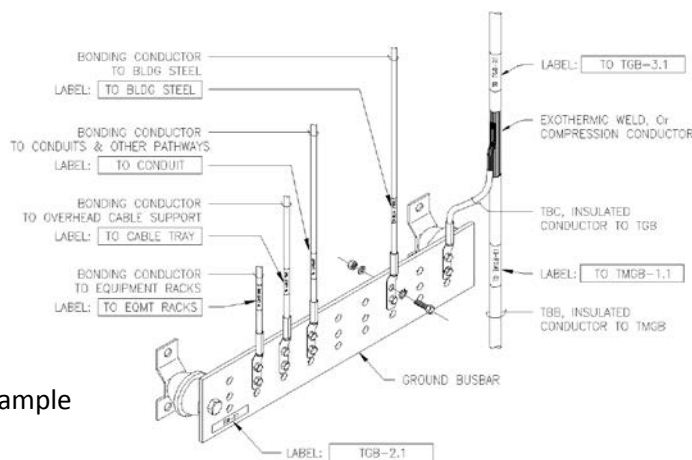

Grounding Bus bar Example

B. Telecommunications Bonding to Grounding Backbone

Metallic components, such as pathways (conduit), overhead cable support, rack bays, etc., within a Telecommunications Room shall be bonded to the respective TGB.

6.2 Electrical Service in Telecommunication Rooms

A. Convenience Outlets (TIA/EIA-569-A-8.3.2.3.10)

Convenience outlets shall be 120V. Convenience outlets shall be circuited from a normal power panel. On walls adjacent to the rack bay (where the rack bay butts up against the wall), provide one quadplex outlet approximately 12 inches in front of the rack bay and one quadplex outlet approximately 30 inches behind the rack bay.

On the other walls, provide two quadplex outlets per wall up to 15 feet. On walls longer than 15 feet, provide two duplex outlets.

B. Rack Bay Service

The rack bay will receive power from a UPS system and power strips.

C. UPS Service

A dedicated electrical outlet shall be provided for the UPS system. The service shall consist of one 120V 20A circuit to an L5-30R receptacle and one 120V 30A circuit to an L5-30R receptacle located behind the rack bay in close proximity to the intended location of the UPS system. Both branch circuit wiring shall be 10 AWG. The Telecom Designer and Electrical Designer shall coordinate the electrical service with the equipment layout. Confirm design draft with Technology Services prior to finalizing. The UPS system with the power strips for rack service will be provided by Technology Services.

D. Security System Service

Coordinate the service requirements with the Security Designer, as the security system will require a dedicated 120V 20A circuit with special termination requirements.

E. Lighting (TIA/EIA-569-A-8.3.2.3.9)

Lighting shall be overhead both in front of and behind the rack bay. Lighting should be dual-lamp fluorescent type, lens not required. Luminance shall be 50 foot-candles measured horizontally at 3 feet above finished floor, minimum.

6.3 Pathways Coordination (CSU 3.1.3)

Pathways can be shown on either electrical or telecom drawings. If shown on electrical drawings (for example, surface raceway), the Electrical Engineer and Telecom Engineer shall carefully coordinate the pathway requirements to avoid missed and/or duplicated requirements, and to ensure component compatibility. Also refer to the sections "OSP Underground Pathways (sec 8.1)" and "Horizontal Pathways (8.6)". These sections provide requirements relative to the electrical pathways (joint trench, conduit types, etc).

7.0 SECURITY

7.1 Access Control for Telecommunication Rooms (CSU 3.2.7 #1)

Telecommunications Rooms require access control. Access control shall be electronic /or a card reader. Only if an electronic card reader is not possible, access control shall be a mechanical dedicated key-type for Technology Services rooms.

The design will depend on construction type (new or renovation) and the room locations within the building (shared with another function such as in a mechanical room).

7.2 Security Equipment, within Telecommunication Rooms (CSU 3.2.7 #2)

The Telecom Designer and the Security Designer shall coordinate the equipment layout / wall elevation within the Telecommunications Room with Technology Services and the Electrical Engineer.

Refer to article 2.1 for a room layout example indicating security equipment coordination within Telecom Room.

8.0 TELECOMMUNICATIONS OSP

8.1 Outside Plant Underground Pathways

A. Conduit Types

The following conduit types will be accepted for the different Circumstances:

Circumstance	Acceptable Conduit Types
Straight Sections, no vehicular traffic	<ul style="list-style-type: none"> Non-Metallic Schedule 40 PVC, concrete encasement not required Non-Metallic Schedule 80 PVC, concrete encasement not required Galvanized Rigid Steel / GRS
Straight Sections, under vehicular traffic	<ul style="list-style-type: none"> Non-Metallic Schedule 40 PVC, with concrete encasement Non-Metallic Schedule 80 PVC, with concrete encasement Galvanized Rigid Steel / GRS
Sweeping Bends	<ul style="list-style-type: none"> Non-Metallic Schedule 40 PVC, with concrete encasement Non-Metallic Schedule 80 PVC, concrete encasement suggested Galvanized Rigid Steel / GRS
Factory Bends/Elbows	<ul style="list-style-type: none"> Non-Metallic Schedule 40 PVC, with concrete encasement Non-Metallic Schedule 80 PVC, with concrete encasement Galvanized Rigid Steel / GRS, with concrete encasement
Building Entrance	<ul style="list-style-type: none"> Galvanized Rigid Steel / GRS, with concrete encasement

B. Maintenance Hole Types (FS 16730- Part3-3.1)

The maintenance holes shall have the following features:

1. Vault-type maintenance holes/pull boxes:

- a) Minimum size (interior clearances) shall be 72-inches wide by 84- inches deep by 120- inches long, using only precast openings for exit and entrance of cables.
- b) Equipped with a sump, corrosion-resistant ladder corrosion-resistant pulling irons, corrosion resistance cable racks, and grounding.

2. Split cover-type maintenance holes/pull boxes: (fs 16730-Part2-2.2)

- a) Minimum size shall be 36-inches wide by 48-inches deep by 60-inches long.
- b) Equipped with a sump, corrosion-resistant pulling irons, corrosion resistant cable racks, and grounding. Entrance and exit is through short side (ends) only.

3. Hand hole-type pull boxes: (FS 16730-Part2-2.2)

- a) Minimum size should be 17-inches wide by 12-inches deep by 30- inches long, installed with a 12-inch deep (minimum) gravel base for drainage.

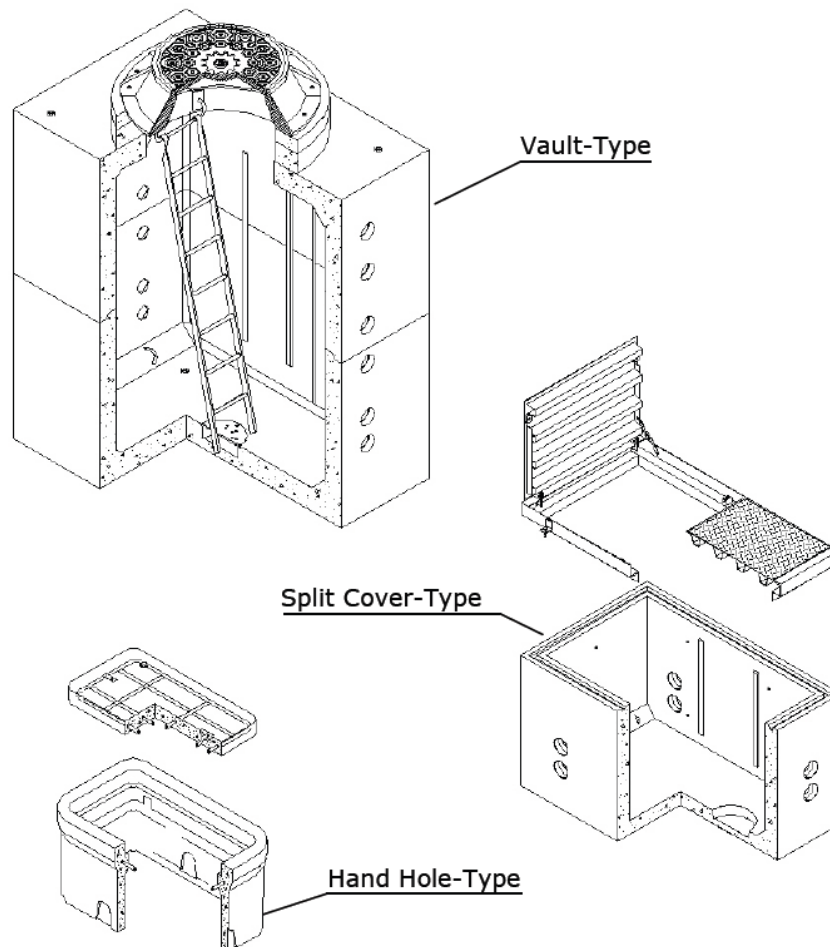

Maintenance Holes Examples

C. Pathway Service per Building (FS 16730-Part2-2.4)

Each building shall receive a minimum of two 4-inch trade size conduits minimum, from the campus' telecommunications underground pathways infrastructure. Within 15 feet of the point where the conduit enters the building, the conduit type shall be GRS (Galvanized Rigid Steel). Non-metallic / PVC conduit will not be accepted.

D. Installation

The minimum burial depth for conduit shall be 36 inches. Duct banks shall not contain more than two 90-degree bends between pull points, and should not exceed 300 feet between pull points. At buildings, install the conduit sloping away from the building with no less than 0.125 inches per linear foot of slope between maintenance holes; install the conduit sloping towards maintenance holes with no less than 0.125 inches per linear foot of slope.

Any penetrations into the Campus OSP will be made using all standard accepted procedures for the boring, placement, and waterproofing of the four inch conduit entering the manhole.

Datacom conduit shall be separated from other underground structures as follows:

Structure	Separation
Power, concrete-encased	3 inches
Power, buried	12 inches

Metallic conduit shall be bonded to the grounding backbone within the telecommunications rooms.

E. Labeling

All conduits and other raceways shall be labeled with permanent type tags. Tags shall include destination and distance engraved onto the tag. Currently we are using red tags with white engraving and a minimum size of 10"X10". Tags will be affixed to the appropriate manhole wall with a permanent adhesive.

F. Building Home runs

All conduits placed for new buildings will be run directly to the nearest MDF. If this is not possible then the conduit runs may go to the nearest manhole, pull box or split-cover box which will be designated by Technology Services. If there are any questions please direct them to Technology Services.

G. Subduct (and Innerduct)

Option 1.

Install 3 each, 1.25-inch trade size (smooth out / ribbed in) in the four inch conduit being used. Each inner-duct shall be uniquely colored and all inner-duct shall have pre-installed tape.

Option 2

Install 1 each, Dura-Line Future Path 4 Way Inner-duct, and 2 each, 1.25-inch trade size (smooth out / ribbed in).

NOTE: The provider has exclusive use of all 4 pathways in the Dura-Line inner-duct, but Fresno State reserves the option of using any available inner-ducts in both options, in the event that other pathways have become impacted or congested.

H. Split Duct

All fiber cable exposed in manholes and entrance vaults will be protected and identified by using an orange ribbed slit duct (Fiber-Guard or Endot). A slack loop of fiber, wrapped once around the manhole. The contents of each piece of split duct will be identified with a factory manufactured, self-laminating, plastic fiber optic label, with the following information: "Type of fiber", "Fiber Count" "Owner of Fiber" and "To and From Locations".

I. Splice Cases

All splice cases will be of the outside plant (3M) reenter able type. Copper splice cases will be water proof and encapsulated with a re-enter-able encapsulate. Fiber splice cases will not be encapsulated, but are required to be re-enter-able. Splice cases shall not rest on the bottom of the enclosure. All splice cases will be attached to the walls, using either the ladder racking or some other means of suspension.

8.2 Telecommunication Rooms

A. Telecom Room Types

The following descriptions summarize the typical telecom room types Technology Services utilizes, along with the room's associated functions.

Service Entrance and Termination Room (MDF/EF) (CSU 2.3.2.1)

This is the main telecommunications building service entrance. It is the area where the carrier MPOE, the demarcation between the interbuilding and intrabuilding cabling systems is affected. This securable room is to be dedicated to this purpose with no other building services sharing the space wherever possible.

Equipment Room (BDF/ER) (CSU 2.3.2.2)

This space provides for the demarcation between inter-building and intra-building telecommunications service. This area contains the electronic equipment that transitions between the core campus data, voice and video backbones and the building backbone. This securable room is to be dedicated to this purpose with no other building services sharing the space wherever possible. This space may be co-located with the Service Entrance and Termination Room, provided the room is sized for both functions

Telecommunications Room (IDF/TR) (CSU 2.3.2.3)

This room provides for demarcation between the horizontal customer service cabling and the building data and voice backbone cabling. Additionally this room contains the electronic equipment that transitions between the data and voice building backbone and the end user telecommunications equipment. This securable room is to be dedicated to this purpose with no other building services sharing the space wherever possible. This space may be co-located with the Service Entrance and Termination Room and/or Equipment Room provided the room is sized for both functions.

B. Environmental Specifications for Telecommunications Facilities

1. Room temperature should be maintained in the range 60°F - 85°F. If this range can be maintained by the incorporation of adequate ventilation means, then mechanical cooling is not required. If this temperature range cannot be maintained by ventilation alone, then mechanical cooling will be required.
2. The relative humidity should range from 30% to 60%.
3. Positive pressure should be maintained at all times to prevent the introduction of contaminants. Exhaust fans shall be considered only as a tertiary means of cooling when all other options have been depleted.
4. The ambient temperature and humidity shall be measured at a distance of five (5) feet above the floor level, after the equipment is in operation, at any point along an equipment aisle centerline.
5. Temperature, and humidity requirements are on a 24-hour, 7 day-a-week basis regardless of the heat generated by normally operating communication equipment.

C. Relevant Specifications Documents (Telecommunications Facilities)

1. ANSI/TIA/EIA-569-B
(Commercial Building Standards for Telecommunications Pathways and Spaces)
- May 2009... Section 7.12.4.2 - Equipment Room Environmental (64°F - 75°F @ 30%-55% RH)

2. Telecommunications Distribution Methods Manual 12th Edition (BICSI) - 2009 Chapter 7-53 - Environmental Controls for Telecom Spaces (68°F - 77°F @ 40%-55% RH))
3. Telecommunications Infrastructure Planning Standards (Third Edition) – May 2007 Section 2.3.2.3, Figure 2-6 - Telecommunications Rooms (60°F -85°F or 65°F /80°F)
ASHRAE (American Society of Heating, Refrigerating and Air-Conditioning Engineers) Environmental Guidelines for Datacom Equipment – 2008 Table 1 (64.4°F – 80.6°F @ 60% RH)

D. Equipment Specific Requirements

Liebert UPS Units	Acceptable Temperature Range: 32°F - 77°F
Liebert External Battery Units	Acceptable Temperature Range: 72°F - 78°F Temperatures above 78°F reduce operating life Temperatures below 72°F reduce battery performance
Cisco Network Switches	Acceptable Temperature Range: 23°F - 113°F Warranty Voiding Temperature: 140°F
Alcatel/Lucent Network Switches	Acceptable Temperature Range: 32°F - 113°F

8.3 Building Pathways (CSU 2.3.3.2)

A. Backbone Pathways

The backbone pathways, namely the conduits from the MDF to each IDF, will be designed per Project. As a default, each Telecommunications Room / IDF shall receive two 4-inch trade size conduits, minimum, from the MDF. Truncate conduits 2” into the rooms. Conduits shall not contain more than two 90-degree bends between pull points, and should not exceed 300 feet between pull points. Pull boxes shall be readily accessible (for example, in a corridor versus a classroom).

Pull boxes shall be straight through and shall not be used for turns. Bends for conduits 3-inch and larger shall be factory fittings minimum 48” radius.

The backbone pathways may also be shared with the Horizontal Primary Pathway – for example, cable tray throughout the building.

At no time may backbone cables lie directly on suspended ceilings and/or be clipped to suspended ceiling support wires.

B. Horizontal Pathways (CSU 2.3.3.3)

Horizontal pathways are facilities that support the installation and maintenance of cables between the telecommunications room and the station outlet locations. In new construction, the designer shall use station conduit stubbed into the false ceiling space.

Telecommunications cables must never be allowed to rest on ceiling tile or be taped or wrapped to other service utilities or conduits. Whenever cable penetrates a smoke or fire-rated barrier, that barrier must be returned to Technology Services original rating based on current NEC specifications. This subsection outlines the major methods recommended within the CSU for supporting cables in the horizontal pathways.

C. Cable Tray (FS 16720-3.7)

A specified cable tray must be sufficient to hold the weight of all the cables likely to be supported over the life of the system, must be routed correctly, and must be installed to maximize usage.

NOTE: Under no circumstances should cable trays ever be painted. If there is painting to be done adjacent to cable trays they should be taped or masked off completely to eliminate the possibility of paint or overspray on them or the cables.

1. Unless otherwise specified by the campus, the cable tray should be NEMA Class Designation 12B (75 lbs. per linear foot). Solid-bottom trays provide better protection from electrical interference than do ladder-type trays. A corrugated ventilated tray, which provides some of the benefits of open-ladder trays and some of the improved protection of a solid-bottom tray, and can be used to meet individual campus preferences. Trays should be 18 inches wide with a minimum depth of three inches. Smaller buildings and secondary tray sections serving fewer than 25 stations may utilize a twelve (12) inch tray. Trays must qualify under NEC Section 318-7(b) as equipment grounding conductors.

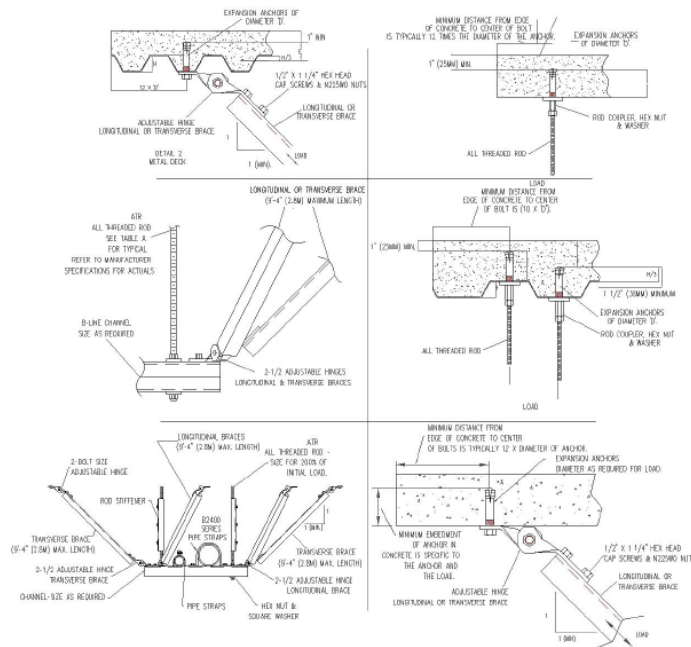
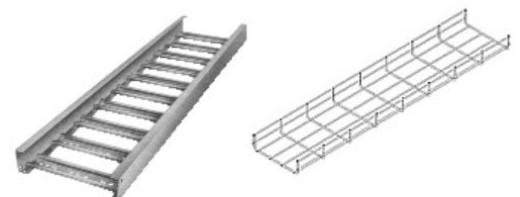

Figure 3 - 21
Typical Cable Tray Supports

2. Trays should be secured on five-to-ten-foot centers using a single center-mounted steel supporting rod and bottom "T" connector, angled wall supports, or a trapeze support. If both sides of the tray cannot be accessed or other limitations prohibit the placement of cable equally in both sides of the tray, a trapeze or wall support system should be used. All tray installations must meet seismic bracing standards for Zone 4 and must be supported against horizontal, lateral, and vertical movement.
3. The cable tray should be routed in a manner that reduces the need for long unsupported cable runs. However, the tray need not be extended to cover all areas of a floor simply to transport cables to one or two locations. Cable installers can utilize appropriately sized "J" hooks to support individual runs of cable, or a zoned conduit system can be used to supplement the cable tray.
4. The cable tray must only be utilized over areas with ceiling access and should transition to a minimum of three four-inch conduits when routed over fixed ceiling spaces greater than 30 feet or containing any angle greater than 20 degrees. Trays should be electrically bonded end-to-end.
5. The cable tray, the support method, the bracing system, and the anchoring components must work together to provide sufficient support for a wide variety of cable types and sizes. It is unlikely the ultimate capacity requirements of an individual cable pathway can be defined as part of a new construction or retrofit project. With the continuous changes in technology and the expanding role of telecommunications in the educational process, forecasting and designing to specific weight capacities is unreasonable. In the absence of campus-provided capacities use Figure 3-22 to determine the capabilities of specific cable tray and ladder rack systems:
6. In retrofit projects it is often more cost effective to use a medium-weight wire mesh cable tray to support the distribution of station cable rather than standard solid bottom or ladder rack style systems. The wire mesh systems are often easier to install and to work around obstructions within existing ceiling space. However, in some cases a solid bottom tray is required to provide physical or electronic protection for the cables being placed.

D. Primary Pathways: (FS 16720-3.7)

The primary horizontal pathways shall be defined as those directly from a Telecommunications Room serving a section (a wing or side) of the building or an entire floor.



Cable Tray

Cable Basket

Images of Typical Primary Pathways

The primary pathway components can be cable basket or cable tray.

Pathway Type and Utilization	Low Usage Capacity)	High Usage Capacity)
<p>Light duty Ladder Rack –generally 12 inches wide made of hollow aluminum.</p> <p>Used within telecommunication rooms to support small feeder and station cables.</p>	12 lbs per foot	28 lbs. per foot
<p>Medium duty cable tray (wire style or solid) generally 9" to 24" wide.</p> <p>Used within buildings to distribute station cable.</p>	12 lbs per foot	30 lbs per foot
<p>Heavy duty cable tray – generally 12 to 18 inches wide made of heavy duty aluminum or solid steel.</p> <p>Used in equipment rooms, main distribution frames (MDF), and service entrance rooms.</p>	18 lbs per foot	50 lbs per foot
<p>Typical cable load for EACH four-inch EMT conduit</p>	4 lbs per foot	15 lbs per foot

Figure 3 - 22

Typical Cable Tray Load Ranges

1. Trays should enter telecommunications rooms six inches into the room, then utilize a drop out in a “waterfall” to protect station cables from potential damage from the end of the tray. Waterfalls MUST be installed prior to the placement of any telecommunication cables. All penetrations through firewalls must be designed to allow cable installers to fire-seal around cables after they are installed. The use of tray-based mechanical firestop systems instead of a transition to conduit is encouraged when a tray must, penetrate a fire barrier.
2. The cable tray must not be placed closer than five inches to any overhead light fixture and no closer than 12 inches to any electrical ballast. A minimum of eight inches of clearance above the tray must be maintained at all times. All bends and T-joints in the tray must be fully accessible from above (within one foot). Trays should be mounted no higher than 12 feet above the finished floor and must not extend more than eight feet over a fixed ceiling area.
3. A separate conduit sleeve (minimum of two inches) must be provided as a pathway through any wall or over any obstruction (such as a rated hallway) from the cable tray into any room having a communications outlet. Such conduit runs must be continuous over fixed ceiling areas, but may be sleeved between false ceiling spaces that have access.

4. A minimum of two four-inch conduits should be dedicated between a telecommunications room and each (raised floor) computer lab or video facility it serves.

Note: “Secondary pathways” may be used as primary pathways when the total cable counts are low enough to allow a lower capacity system. Lower cable counts are approximately 50-100 cables, maximum, throughout an IDF’s service area.

7. Secondary Pathways: (FS 16720-3.7)

The secondary horizontal pathways shall be defined as those from the primary pathways serving an area of a section or to specific devices. The secondary pathway components can be cable hangers or, as an alternative, “Snake Tray”.

Example: Cable Hanger “Snake Tray Series 201”

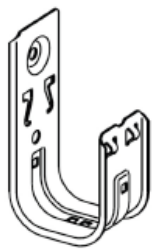

Cable Hanger

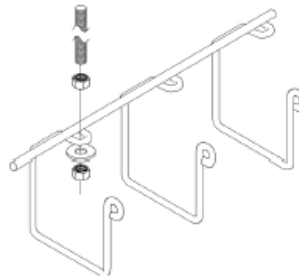

“SnakeTray Series 201”

Images of Typical Secondary Pathways

E. Device Pathways (FS 16720-3.8)

The device pathways shall be defined as the pathway supporting a single compliment of cabling to a single device within a User Space.

For all installation configurations requiring a conduit stub, the conduit shall be 1-1/4 inch trade size, minimum. Stubs shall be continued to the first accessible location, or above the accessible ceiling tile.

For all installation configurations requiring a device box, the box shall be 4-11/16” square or 4” square, and shall be 2-1/8” deep, minimum.

The following descriptions shall be used to plan the configuration of telecom devices throughout the building. These descriptions are for planning purposes and the exact configuration shall be finalized per instance.

1. Framed Wall, for both New Construction and Renovation:

The device pathway at framed walls shall be conduit stub from an accessible space (such as acoustical tile ceiling) to a device box within the wall interstitial. The device box should be installed at +18 inches for typical outlets or as coordinated by the Architect.

Note: In remodeling locations without fire barriers or in filled walls where cable can be “fished,” a faceplate support bracket may be used. Faceplates without the use of the support brackets are not allowed. The best design provides an EMT conduit from above the ceiling space to just above the point at which the faceplate is to be mounted.

2. Concrete Wall, for New Construction:

The device pathway at concrete walls should be buried (cast within the forms) into the wall.

3. Concrete Wall, for Renovation:

The device pathway at concrete walls shall be either conduit surface mounted to a device box surface-mounted, or surface raceway to a device box surface-mounted.

4. CMU (Concrete Masonry Unit) Wall, for both New Construction and Renovation:

The device pathway at CMU walls shall be either conduit surface mounted to a device box surface-mounted, or shall be surface raceway to a device box surface-mounted.

5. Floor Devices, for both New Construction and Renovation:

The device pathway for in-floor type instances shall be buried (cast within the forms) into the floor.

For poke-thru type instances, no special device pathway is required as the cables will be routed within standard building pathways on the floor below to the poke-thru device.

6. In-Ceiling Devices, for both New Construction and Renovation:

The device pathway for in-ceiling devices shall be a device box installed either on the structure above or onto a channel at an accessible height above an accessible ceiling. The cables will be routed within standard building pathways to the device box.

7. Pathways within Classroom for AV

Refer to Instructional Technologies section for requirements on pathways.

8.4 Backbone Fiber Optic Cabling (CSU 3.3.1)

A. Cabling Deployment

New buildings shall receive new interbuilding backbone singlemode fiber optic cabling and new interbuilding backbone twisted pair cabling from the campus MDF.

1. New Buildings

New buildings shall receive new campus backbone singlemode fiber optic cabling and new campus backbone twisted pair cabling from the campus MDF.

2. Renovated Buildings

If the building to be renovated does not have singlemode fiber service from the MDF, the building shall receive new campus backbone fiber optic cabling from the campus MDF.

If the building to be renovated does not have twisted pair service from the MDF, the building shall receive new campus backbone twisted pair cabling from the campus MDF.

B. Outdoor Backbone Fiber Optic Cable Type (FS 16725-2.5)

Backbone fiber optic cables installed outdoors shall be loose buffered.

For installation within innerduct, backbone fiber optic cables shall have a sheath consisting of a polyethylene jacket over the inner cable components (buffer(s), strength element, and other components). The cable shall be dielectric.

For installation without innerduct, backbone fiber optic cables shall have a sheath consisting of a polyethylene outer jacket, an armor (corrugated metallic tape), and should have an inner jacket, all over the inner cable components (buffer(s), strength element, and other components).

Technology Services prefers dielectric cable and innerduct over no innerduct and armored cable, where possible. A dielectric cable is easier to work with, is electrically non-conductive (won't conduct transient voltages), and including an innerduct allows easier cable demolition and replacement (if necessary).

The Designer shall confirm with TECHNOLOGY SERVICES prior to finalizing the design.

- 1. NOTE:** Per NEC (National Electric Code), there is a 50 ft. maximum distance unlisted cable can be run into a building. Articles 770, 800, and 820 each have paragraphs that describe how unlisted cables shall be permitted to be installed where the length of the cable within the building, measured from the "point of entrance", does not exceed 50 ft and the cable enters the building from the outside. The individual articles address their own cables' uniqueness and further define if the cable has to be terminated in an enclosure, a protector panel, or a grounding block. The NEC was helpful in defining the unlisted cable distance the same for each article. The trades commonly refer to the unlisted cable past the entrance point as the "50-ft rule."

Though in the simplest terms, 50 ft. is the maximum distance of unlisted cable that can be routed into a building; you can actually run more than 50 ft. The key is in understanding what the NEC defines as the point of entrance. Articles 770, 800, 820, and 830 have similar definitions for the point of entrance. In those articles, "point of entrance" means the point within a building at which the wire or cable emerges from an external wall, from a concrete floor slab, or from a rigid metal conduit (type RMC) or an intermediate metal conduit (type IMC) connected to a grounding conductor to an electrode.

For cables defined in 770, 800, and 820, if the unlisted cable that enters the building is immediately exposed, you need to start counting 50 ft of cable from the wall or concrete slab. You can provide protection to the cable using inner-duct cable tray or electrical metallic tubing (EMT) raceway, but the 50-ft limit starts where the cable exits the wall of concrete slab.

To extend into a building beyond 50 ft., the conduit entering the wall or concrete floor slab needs to be extended with IMC or RMC conduit. This allows the entrance point to move from the wall or concrete slab. The 50-ft limit starts when the cable exits the IMC or RMC conduit. Extending the entrance point with IMC or RMC is a useful provision in applications when it is not practical to have the entrance facility on a ground floor or adjacent to the exterior of the building.

This is based on the “point of entrance” and NEC defines “point of entrance”, (in Articles 770, 800, 820, and 830), as the point within a building at which the wire or cable emerges from an external wall, from a concrete slab, or from a rigid metal conduit (type RMC). Our MDF cable vaults are not considered manholes, but are designated as part of the building structure, therefore, once the cable exits the conduit penetrating the outside wall the 50 ft. limitation starts.

C. Indoor Backbone Fiber Optic Cable Types (FS 16725-2.5)

Backbone fiber optic cables installed indoors shall meet the rating required by the authority having jurisdiction, Technology Services.

Backbone fiber optic cables installed indoors shall be tight buffered.

Backbone fiber optic cables installed indoors should have a sheath consisting of an integral strength element with a thermoplastic outer jacket over the inner cable components (buffered fibers, strength element, and other components).

D. Fiber Types

New singlemode fibers shall be 8.3/125 μ m, with a maximum dispersion of 3.5 ps/nm•km at 1285-1330 nm, and a cutoff wavelength of 1260 nm.

E. Cable Capacity / Conductor Count

1. Campus Backbone Fiber Optic Cabling

Campus backbone fiber optic cabling links shall contain a minimum of 24 singlemode strands. Confirm the strand counts with Technology Services.

2. Intrabuilding Backbone Fiber Optic Cabling

Intrabuilding backbone fiber optic cabling links shall contain a minimum of 24 singlemode strands. Confirm the strand counts with Technology Services.

F. Splicing (FS 16725-3.5C)

Where fiber splicing is explicitly stated in writing, the splicing shall be fusion. No mechanical splicing will be accepted.

G. Termination

1. Connectors (TIA/EIA-568-B.3, section 5.0)

Singlemode fibers shall be terminated via singlemode SC connectors.

SC connectors shall be 568SC type, and shall meet all requirements of TIA/EIA-568-B.3, section 5.0 including references. The connector housing and the boot shall be blue in color.

2. Patch Panel

The patch panels shall be rack-mount type and shall be installed into an equipment rack, preferably in the top RMU. Coordinate the final location with Technology Services. Provide one patch panel for multimode termination and one patch panel for singlemode termination – as applicable.

3. Adapters

Adapters within the patch panels shall meet all requirements of TIA/EIA-568-B.3, section 5.0 including references. Singlemode adapter housing shall be blue in color and shall be simplex.

H. Backbone Fiber Optic Cabling Testing

Each fiber strand requires testing using the (TIA) ANSI/TIA/EIA-568-B.1 or (ISO) ISO/IEC 11801 Ed.2 Standard. The testing shall be bi-directional characterization testing (via OTDR) and passive link insertion loss test (via light source and power meter).

Prior to 'production' field testing, the Designer, with the Installer, shall observe the testing methods. The purpose for this is to approve the methods prior to completing testing activities only to have a flawed method yielding non reliable test results.

8.5 Backbone Twisted Pair Cabling

A. OSP Backbone Twisted Pair Cable Type (FS 16725-Part 2-2.1)

Backbone twisted pair cables installed outdoors shall be gel-filled and should be ANMW type, with an ASP sheath.

B. OSP Backbone Twisted Pair Cable Capacity / Conductor Count OSP backbone

Twisted pair cabling links should contain a minimum of 50 pairs or confirm conductor count with TECHNOLOGY SERVICES per Project.

C. OSP Backbone Twisted Pair Cabling Entrance Termination

Backbone twisted pair cabling links entering from underground from the Campus shall be spliced to building entrance protection terminals, wall mounted.

See following diagram.

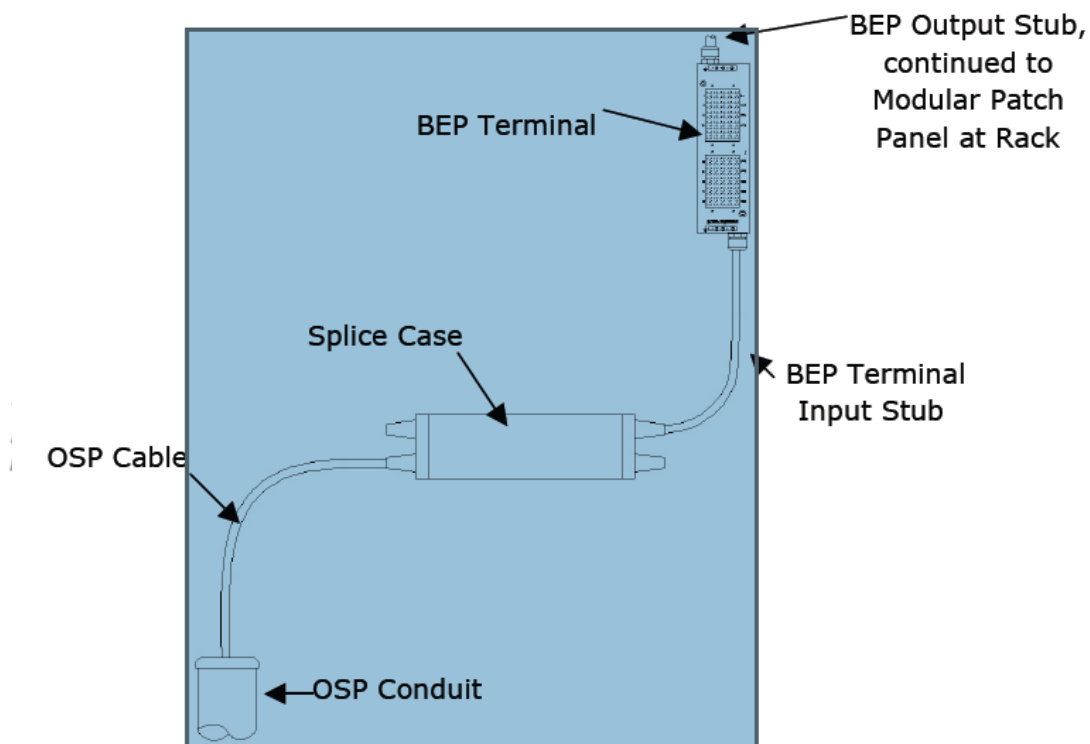

Backbone OSP Twisted Pair Cable Termination Example

D. Indoor Backbone Twisted Pair Cable Types (CSU 4.2.2)

Backbone twisted pair cables installed indoors shall meet the rating required by the authority having jurisdiction, Technology Services. Backbone twisted pair cables installed indoors should ARMM type.

E. Indoor Backbone Twisted Pair Cable Capacity / Conductor Count (CSU 4.2.3)

Indoor backbone twisted pair cabling links should contain either 25 pairs or 50 pairs to each IDF. Confirm conductor count with Technology Services per project

F. Backbone Twisted Pair Cabling Termination

Backbone twisted pair cabling links, including output stubs from BEP terminals (see prior paragraph), shall be terminated to modular patch panels on an equipment rack. Refer to Horizontal Cabling for modular patch panel specifications. The following diagram depicts the intent for the backbone twisted pair cable termination.

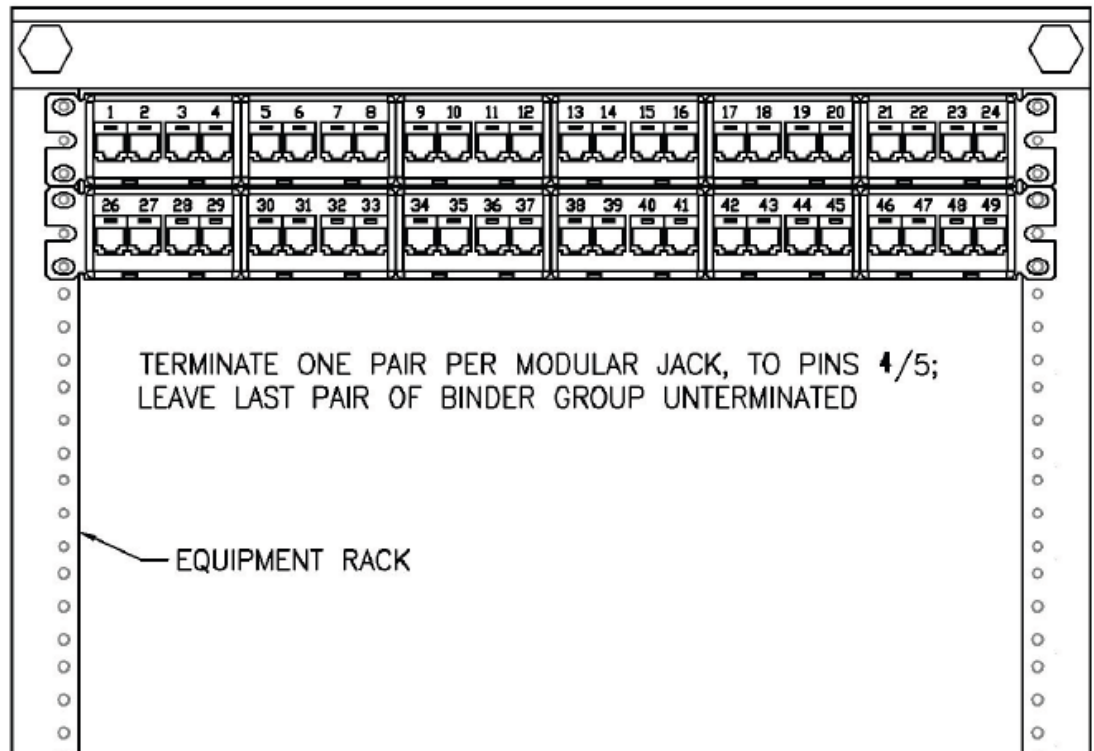

Backbone Twisted Pair Cable Rack-Mount Termination Example

G. Backbone Twisted Pair Cabling Testing

Backbone twisted pair cabling links shall have 100% of the pairs tested for wire map and one pair from each 25-pair binder group tested for length.

8.6 Horizontal Cabling

A. Horizontal Cable Type

Horizontal cables shall meet the rating required by the authority having jurisdiction, Technology Services. Assume that all cables shall be CMP (plenum) rated. Horizontal cables shall be twisted pair type, with four twisted pairs, and should have a CMP rated sheath and have a 24" service loop above ceiling at jack location. Service loop at closet end will be determined by the closet size.

B. Horizontal Cables in Underground Conduit

If there are only a few connections required in a detached shop, shed or outbuilding, Cat 6 cable can be run in underground conduit between buildings. There is no TIA/EIA or ANSI regulation that prohibits this, but there are four criteria that need to be addressed:

- The distance must be less than the 295' maximum distance.
- If water is an issue then gel protected Cat 6 cable with proper damming and protection on at least one end is required, otherwise indoor/outdoor Cat 6 cable is acceptable.
- The Cat 6 cables must terminate in the closest TR.
- If Fire Alarms or Pull Stations are required in building, two copper cables MUST be pulled in for alarm lines to stay in accordance with the State Fire Marshal.

The above being said, depending on the potential future demand of the network, the proper choice might be to run fiber between the locations and place a switch in the shop, shed, or building, thus allowing for growth or change depending on the use of the building.

C. Link Performance

Link performance shall be Category 6 and must comply with (TIA) ANSI/TIA/EIA-568-B.1 or (ISO) ISO/IEC 11801 Ed.2 Industry Standards.

D. Telecommunications Room Termination (CSU 4.2.3.1 #6)

In the Telecommunications Rooms, cables shall be terminated via modular jacks in a rack-mounted modular patch panel. Also refer to "Modular Jacks" following.

Modular patch panels shall be discrete port type (snap-in modular connectors). Coordinate layout of patch panels in rack through Technology Services.

E. Workstation Termination (CSU 4.2.3.2)

At the workstations, cables shall be terminated via modular jacks – refer to "Modular Jacks" following.

F. Modular Jacks

All modular jacks, including wallphones, shall be 8-position 8-conductor type connectors, compliant with T568B wiring..

G. Service, Per Work Area

A "link" shall consist of a single cable, termination in the datacom room and termination at the work area. Termination in the datacom room shall consist of one port on a patch panel. Termination at the work area shall consist of one modular jack (one per cable) into a faceplate within appropriate device pathways.

- A "standard device" shall consist of three links, minimum, to a single device.
- A "classroom device" shall consist of one link, minimum, to a single device.
- A "wall phone device" shall consist of one link to a single device. The faceplate shall be an "860" type with 2 mounting studs

The maximum quantity of links per device shall be six. If the service requirement at any instance is greater than four, then specify multiple devices to meet this requirement.

Fixed Office:

Fixed offices (typically 10' X 10') shall receive at least two standard devices, on any wall. If the fixed office is large enough and intended to support multiple workstations, add one standard device per additional workstation.

Open Office:

Generally, open offices shall receive one standard device per workstation.

Conference Rooms:

Conference rooms shall receive at least two standard devices, generally on opposing walls. If the conference rooms have video projection or are intended to support multiple workstations, contact Technology Services for each instance.

Classroom:

Generally, classrooms shall receive three classroom devices – one at the front of the room, one at the back of the room, and one in the ceiling (for projector). Classrooms shall also receive one wall phone device, located adjacent to the door. Contact Technology Services for each instance requirements.

Computer Lab:

Computer labs shall receive one link per computer station and printer (assume one printer per six computers).

WLAN Access Point:

Access points shall receive two links. The deployment shall be determined per project as the coverage area is building-specific (refer to Wireless LAN Service article following). Also, the installation shall vary per instance (wall mount, ceiling mount . . . etc.).

Telecom Room (TD):

Telecom Rooms shall receive one wallphone device, located adjacent to the equipment.

Elevator:

Elevators shall receive one link to the elevator control panel.

Copy Machine:

Copy machines shall receive two links, wall-mounted behind the equipment.

BMS:

BMSs (building management system control panel) shall receive two links, located within 5 feet of the panel but outside of it.

Fire Alarms:

Fire Alarms shall receive two links terminated outside of the alarm control panel.

ACAMS Panel:

ACAMS (access control and monitoring system) control panels shall receive two links, located within the panel.

8.7 Station Cabling

A. Copper Station Cabling

Any placement of station cables for use for voice or data applications to interconnect services from workstation to the wiring closet in a plenum or non-plenum rated space must meet the following requirements:

1. Compliance: UL 444, UL 910, UL 1666 ISO/IEC 11801-1995, ANSI/TIA/EIA 568-B.2, NEC Listed MPP/CMP, Verified to category 6 as defined by EIA/TIA standards intended for use with transmission rates up to and including 100 Mbps.
2. Make up: Four unshielded twisted pair, 24 AWG, solid annealed bare copper conductors insulated with FEP and covered with a flame retardant PVC jacket.
3. All copper station cable shall be Category 6, Plenum rated.
4. Station cables shall have a color jacket as follows:
 - Blue – Analog/Digital or Data
 - Yellow – Data 1
 - White – Data 2NOTE: Jacks are the same color as cable jacket
Orange- Power Meters
5. Maximum cable length not to exceed 100m or 300'.
Manufacturer: Manufacturer must meet requirements of selected Structured Cabling System for Superior Essex.
6. Cat 6 Certification testing must comply with (TIA) ANSI/TIA/EIA-568-B.1 or (ISO) ISO/IEC 11801 Ed.2

B. Coaxial Station Cabling

Any placement of coaxial building drops must meet or exceed NEC Specifications and characteristics listed below:

Use RG - 6 cables, plenum-rated with a bonded foil aluminum shield having 100% coverage, it will be constructed with an outer aluminum braid shield with 67% minimum coverage. Foamed

Teflon dielectric with a .04 inch copper clad steel center conductor will be required and Impedance will be 75 Ohms. It will support frequencies between 5-1000 MHz. and have a nominal attenuation not to exceed 5.78 dB per 100 feet at 600 MHz. Manufacturers: Commscope F677TSVV, or approved equivalent.

C. Coaxial Station Cable Connectors

The “F” style connectors for the RG-6 station cable shall be equipped with an integral ribbed crimp ring. Only a connector recommended by the cable manufacturer shall be installed. Only the connector manufacturer’s recommended crimping tools shall be used for all F-56 connectors.

Manufacturers: Gilbert Engineering Co., Inc., Thomas & Betts, Corp., Stirling, or approved equivalent.

8.8 Faceplate Requirements

A. Work Areas

The work area is spaces in a building where occupants (users) normally work and make use of their telecommunications devices. Major work area components include the telecommunications outlet, work area station cable (cord), and work area devices. Work area devices include telephones, modems, printers, fax machines, and computers. Each of these devices requires access to the horizontal cabling via a cord plugged into the telecommunications outlet located within the work area.

A telecommunications outlet can support any type of connecting device located in the work area on which plenum horizontal cable terminates. A telecommunications outlet is considered a 4-pair cable terminated on both ends with RJ45 jacks. This connector is recognized as an industry standard for balanced twisted-pair cabling. These twisted-pair horizontal cabling require each 4-pair cable to be terminated to an 8-position, 8-contact (8P8C) modular jack at the work area according to T568B pin/pair assignments. The horizontal balanced twisted-pair cabling must be Leviton-Plenum cable and meet the latest ANSI/TIA/EIA-568 revisions for Category 6 cabling specifications.

Note: All faceplates are identified as shown below and this is the campus standard

B. Types of Faceplates

1. Basic/Wall Faceplate

The Basic module design supports voice or data applications on one telecommunications outlet by one 4-pair Leviton-Plenum Unshielded Twisted Pair (UTP) Category 6 Blue colored cable. A basic design is used for phones, card readers, or to augment an existing work area with additional voice or data capacity.

For classroom and lab situations that do not require any data connections, at least one location for a wall set is required. It will be installed at the required ADA height (48") with a Category 6 RJ45 jack and faceplate. This faceplate must be stainless steel and have the ability to secure a wall set to it. The part number for this faceplate is Leviton 4108W-SP. It will be labeled with the appropriate room, jack and port number.

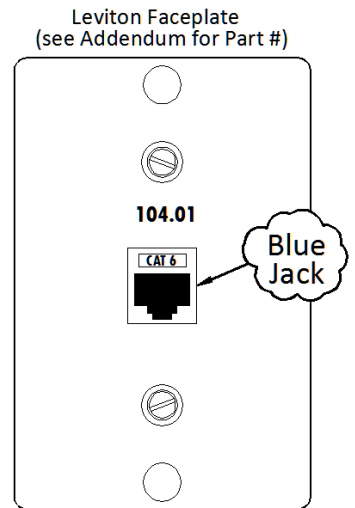

CAT 6 Basic/Wall Faceplate

2. Standard/Integrated Faceplate

The Standard module design supports voice and data applications on three distinct telecommunications outlets by three individual 4-pair Leviton-Plenum UTP Category 6 cables (a blue, yellow, and white cable) each terminates on separate telecommunications connectors (a blue, yellow, and white jack). Faceplate labeling will be done mechanically and the labeling font size will be 24 point, (3/8"). The standard outlet is the most commonly used configuration at Fresno State. Patch panel information will be supplied by Technology Services. The Integrated module design supports complex systems including voice, data, and video applications. An integrated module consists of three or more 4-pair Leviton-Plenum UTP Category 6 cables supporting each terminate on separate telecommunications connectors.

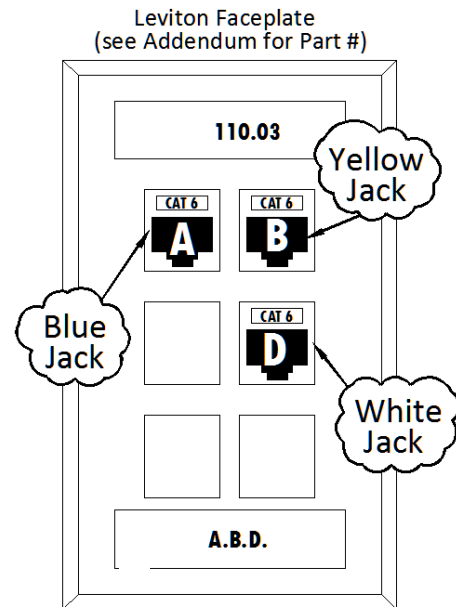

Standard/Intergrated Faceplate

3. Dual Faceplate

In addition to the above example, there are several other types of faceplate configurations that are used on campus. If there are two adjacent work stations they may both be placed in the same faceplate, as shown in the figure to the right. In the Dual Station Faceplate, one station uses the jacks on the left side of the faceplate and the second work station uses three jacks on the right side of the faceplate. There is a blue, yellow and white cable pulled for each station. The blue Leviton Category 6 RJ45 jack is used for voice or data connections, and is always in the uppermost jack cutout. The yellow Leviton Category 6 RJ45 jack is used for primary data connection, and it is in the middle faceplate cutout. The white Leviton Category 6 RJ45 jack is located in the bottom jack cutout. Faceplate labeling will be done mechanically and the labeling font size will be 24 point, (3/8".) Patch panel information will be supplied by Technology Services.

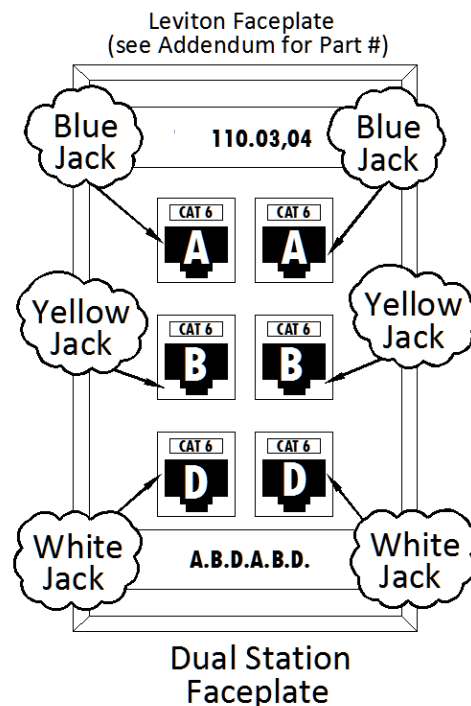

4. Data Faceplate

Fresno State utilizes a configuration in our computer labs or in locations where there is a high concentration of data connections. These are called Data Station Faceplate connections and may include as many as six data connections. These are all yellow Leviton Category 6 RJ45 jacks and are placed and counted from the top left down. All cables to be pulled are yellow cables. Note that lettering is used for the jack location of the faceplate and numbers are used for the actual jack location in the room. Faceplate labeling will be done mechanically and the labeling font size will be 24 point, (3/8".)

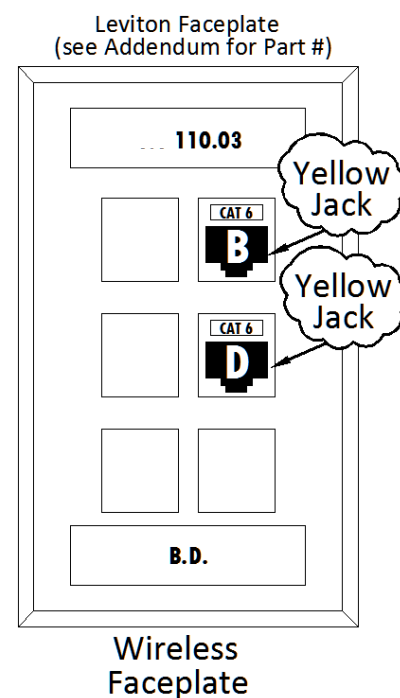

5. Wireless Access Points Faceplate

For wireless connections Fresno State will require a faceplate with two connections. Technology Services makes final determination for location of WAPS. They are yellow Leviton Category 6 RJ45 jacks placed on both the faceplate end and the patch panel end of the cable. They are placed the same location as the example to the right and all vacant ports on the faceplate will have blanks installed on them. The cables that are pulled for them are yellow. This faceplate is almost always in the ceiling and the room faceplate designations require that these faceplates will be assigned faceplate numbers after all of the wall outlets have been identified. Faceplate labeling will be done mechanically and the labeling font size will be 24 point, (3/8”).

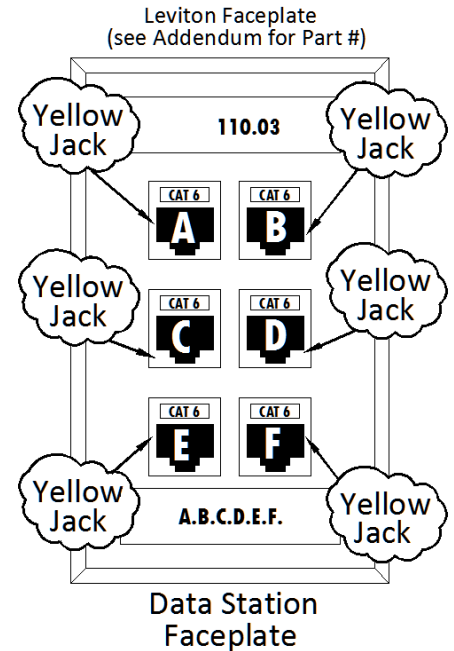

6. LCD Projector Faceplate (PTV))

For LCD Projector connections Fresno State will require a faceplate with two connections. They are yellow Leviton Category 6 RJ45 jacks placed on both the faceplate end and the patch panel end of the cable. They are placed the same location as the example to the right and all vacant ports on the faceplate will have blanks installed on them. The cables that are pulled for them are yellow. This faceplate is always in the ceiling and room faceplate designations require that these faceplates will be assigned faceplate numbers after all of the wall outlets have been identified. Faceplate labeling will be done mechanically and the labeling font size will be 24 point, (3/8”).

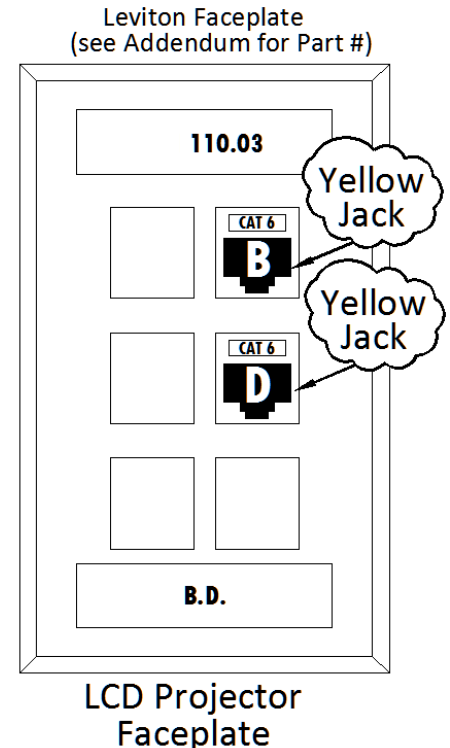

7. Television Faceplate (TV)

For Television connections Fresno State will require a faceplate with two connections. They are yellow Leviton Category 6 RJ45 jacks placed on both the faceplate end and the patch panel end of the cable. They are placed the same location as the example to the right and all vacant ports on the faceplate will have blanks installed on them. The cables that are pulled for them are yellow. Room faceplate designations are assigned in room rotation, just like other wall faceplates. The faceplate designations will be assigned by Technology Services. Faceplate labeling will be done mechanically and the labeling font size will be 24 point, (3/8".)

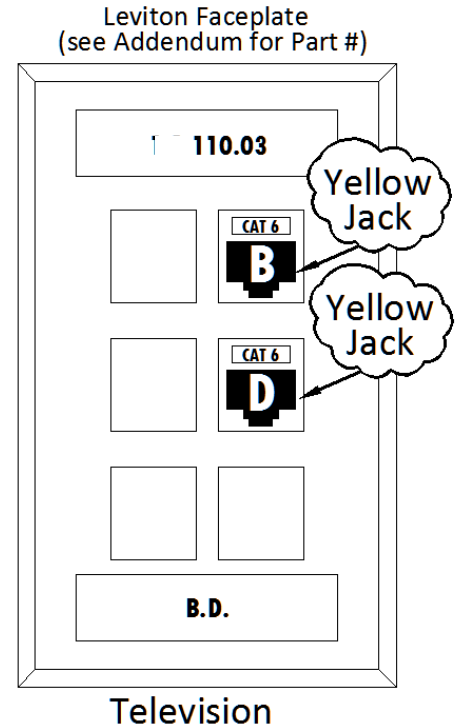

8. Blackboard Faceplate

For Blackboard connections Fresno State will require a faceplate with two connections. They are yellow Leviton Category 6 RJ45 jacks (611110-RY6) placed on both the faceplate end and the patch panel end of the cables. They are placed adjacent to the Blackboard panel mounted on the outside of the panel. All vacant ports on the faceplate will have blanks installed on them. The cables that are pulled for them are Superior Essex Cat6 yellow cables (P4P24-YL-P-ESS-AP). The faceplate designations require that these faceplates will be assigned patch panel positions 47 and 48 of the last patch panel and labeled BLKBD01B and BLKBD01D on both ends with a mechanical labeler and NOT handwritten. The door or controller will be terminated in a Quickport single gang 6 port faceplate as shown on the right.

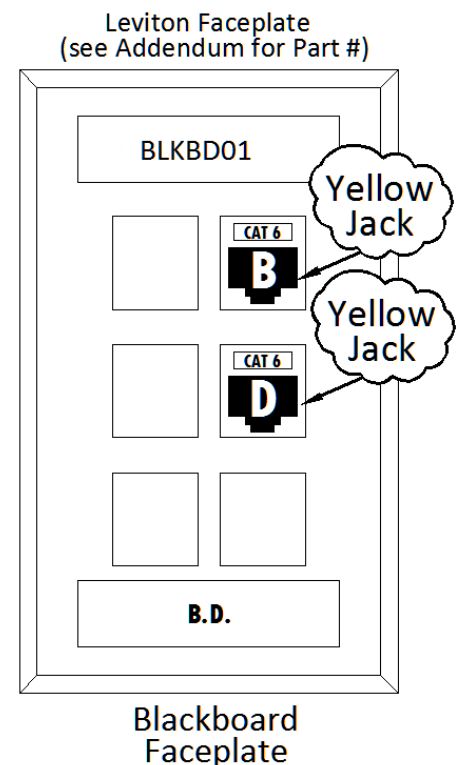

9. Fire Alarm Faceplate

For Fire Alarm connections Fresno State will require a faceplate with two connections. They are yellow Leviton Category 6 RJ45 jacks (611110-RY6) placed on both the faceplate end and the patch panel end of the cables. They are placed adjacent to, but not inside of the Fire Alarm Panel. All vacant ports on the faceplate will have blanks installed on them. The cables that are pulled for them are Superior Essex Cat6 yellow cables (P4P24-YL-P-ESS-AP). All labeling done on both ends will be with a mechanical labeler and NOT handwritten. Note: Contactor may use a two port faceplate, this is acceptable with the University.

10. Camera Faceplate

For Camera connections Fresno State will require a faceplate with two connections. They are yellow Leviton Category 6 RJ45 jacks (611110-RY6) placed on both the faceplate end and the patch panel end of the cables. They are placed the same location as the example to the right and all vacant ports on the faceplate will have blanks installed on them. The cables that are pulled for them are Superior Essex Cat6 yellow cables (P4P24-YL-P-ESS-AP). The faceplate designations require that these faceplates will be assigned as CAMXXX, (XXX= faceplate numbers assigned by Technology Services) and both ends will be labeled with a mechanical labeler and NOT handwritten and the labeling font size will be 24 point, (3/8".) The jacks will be terminated in a Quickport single gang 6 port faceplate as shown on the right.

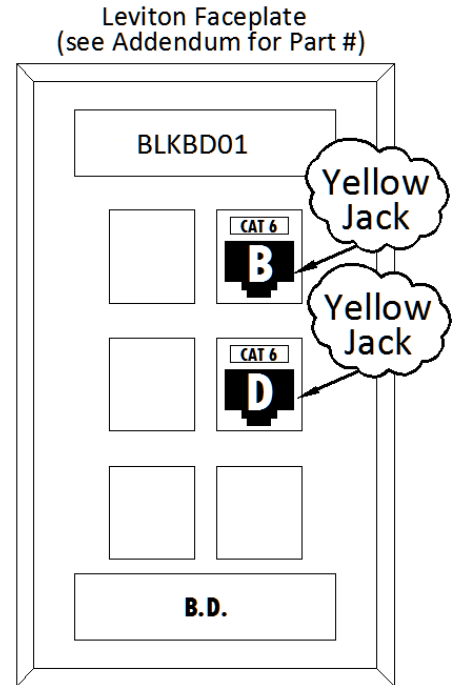

Fire Alarm Faceplate

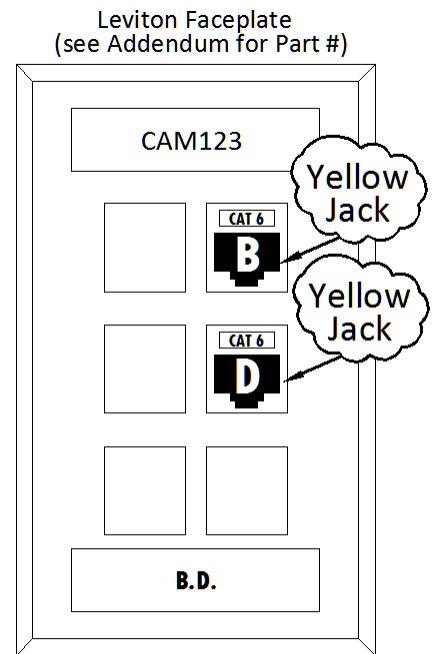

Camera Faceplate

11. Energy Management Systems Faceplate (EMS)

For EMS connections Fresno State will require a faceplate with two connections. They are yellow Leviton Category 6 RJ45 jacks (611110-RY6) placed on both the faceplate end and the patch panel end of the cables. They are placed outside of and adjacent to the panel. All vacant ports on the faceplate will have blanks installed on them. The cables that are pulled for them are Superior Essex Cat6 yellow cables (P4P24-YL-P-ESS-AP). The faceplate designations will be assigned by Technology Services and by no means are ever terminated INSIDE the EMS cabinets. Cables are identified on both ends with a mechanical labeler and NOT handwritten. The EMS Jack will NOT be terminated inside the EMS cabinet and will be terminated in a Quickport single gang 6 port faceplate as shown on the right.

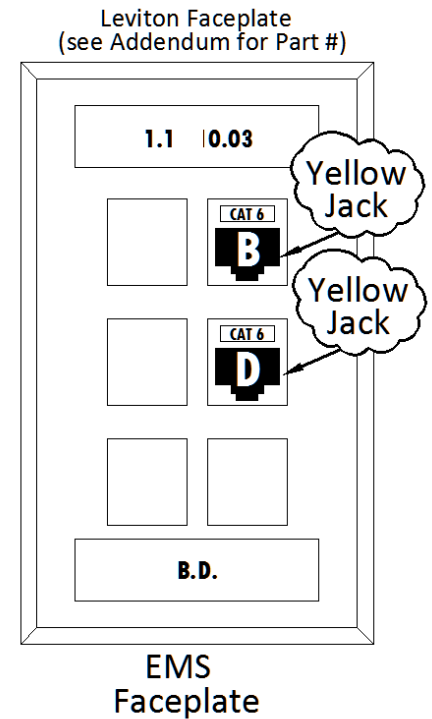

12. Power Meter Faceplate

For Power Meter connections required in newer buildings Contractor will place an Orange Jack in a single port faceplate (Note: This is the only circuit that will use a single port at Fresno State). If Power Meter is located in the building, Superior Essex Cat6 orange cable (P4P24-OR-P-ESS-AP) will be used. If meter is located outside of the building then Superior Essex Cat 6 OSP Broadband BBD cable will be used. Locations will be determined by Technology Services. Faceplate labeling will be done mechanically and the labeling font size will be 24 point, (3/8".)

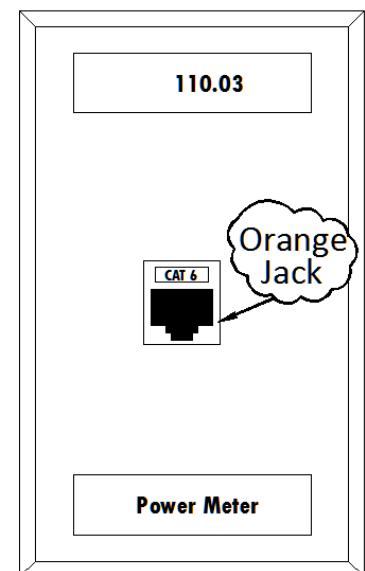

NOTE: All the above jacks listed are the Leviton Extreme 6+ jacks and their current part numbers are as located in the Addendum at the end of this document. Any deviations or changes MUST be approved by Technology Services prior to installation.

The faceplates are Leviton white or international white contact Technology Services for exact color. Blanks are required to cover any open jack appearances and they are also white or international white.

C. Station Outlet Requirements

The "standard" wall outlet should be a steel 4 inch square 5/8 In. raised one gang cover attached to the stud and served by a 1¼-inch conduit (with no more than a total of 180 degrees of bend). Outlets should be mounted as defined by code. Telecommunications outlet boxes should never be daisy-chained or mounted back-to-back using a common feeder conduit.

In locations without fire barriers or in filled walls where cable can be "fished," a faceplate support bracket may be used. Faceplates without the use of the support brackets are not recommended. The best design provides an EMT conduit from above the ceiling space to just above the point at which the faceplate is to be mounted.

If flush-mounted floor outlets are required, the designer should place a dual use (communications & power) preset outlet in the floor surface and feed the conduit (1¼" for communications only) through the floor slab to the nearest wall and up into accessible ceiling space. Flush-mount units must provide a space for telecommunications comparable to the standard NEMA outlet box.

If a large number of such outlets are required, the designer should consider the use of cast-in-place floor boxes with feeder duct (Walkerduct) served by multiple two-inch conduits directed into the ceiling space.

Custom counter or workstation installations requiring telecommunications services should be connected to a wall mounted junction box fed by a two-inch conduit. A maximum of four workstations can be jointly served in this manner.

Classrooms, labs and lecture halls will require additional connecting communications conduit between the faculty teaching position and the room display system. If the room is to be equipped with a ceiling-mounted projection system, a 1½" conduit terminating in a 4 11/16 inch square outlet box must be linked to the instructor's communications/power outlet. A pull box (6"x6"

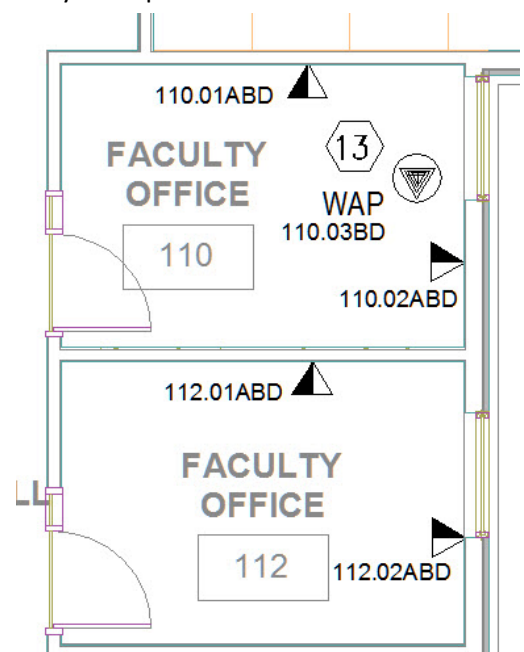

minimum) should be provided in line with the conduit to limit the number of bends to a total of 180 degrees. The display system (overhead projector, wall-mounted video, ceiling speakers) will require a separate conduit distribution tied to a control point, generally the instructor's position, and must be professionally designed to meet the needs of the specific facility. Contact Technology Services in each instance.

In some laboratories, work areas, and/or counter spaces, wall-mounted wire mold should be utilized to distribute communications to a variety of user locations. This raceway must be metal (and must be grounded) and at a minimum be 1½" x 4". The communications portion of the raceway should be fitted with standard NEMA duplex outlet knockouts for mounting the communications jacks. The designer should provide for multiple access points into the raceway, and place a minimum of two 1½" feeder conduits into every eight feet of raceway section.

D.Faceplate Designations

All faceplates will be given a unique faceplate number. It will be determined by the BDF/IDF (Building Distribution Frame or Intermediate Distribution Frame), the room number and the jack number. NOTE: Architectural drawing room numbers are **NOT** accurate; it is the responsibility of the installer to verify with Technology Services the correct faceplate designation. As a rule, the numbering is usually determined by the assigning the jacks in a clockwise manner in the room. See sample diagram on right.

E.Work Area Design Considerations

Administrative Work Areas

A minimum of two Standard Faceplates is provided in each office. The telecommunications outlets should be located to offer maximum flexibility for change in the work area, i.e., on opposing walls.

Conference Rooms

Provide a minimum of two Standard Faceplates in each conference room.

Large Classrooms (over 50 occupants)

Provide at least one Basic/Wallphone Faceplate in each large classroom. Large classrooms require additional telecommunications requirements. Contact Technology Services in each instance.

Small Classrooms

At least one Basic/Wallphone Faceplate in each small classroom. Small classrooms require additional telecommunications requirements. Contact Technology Services in each instance.

Public Areas

At least one Standard Faceplate is provided in public areas.

Laboratories

Provide at least one Standard Faceplate in each laboratory.

Laboratories require additional telecommunications requirements. Contact Technology Services.

Special Use Telecommunication Modules

Provide at minimum one Standard Faceplate adjacent to the building environmental control panel.

Provide at minimum one Standard Faceplate adjacent to the building fire alarm panel.

Provide at minimum Basic/Wallphone adjacent to the elevator control panel for an emergency telephone.

8.9 Administration / Labeling

General

Labels, tags, and straps shall be high quality that will endure over the life of the cable plant. Hand written labels are not acceptable.

Cable labels shall be self-laminating. Cable labels shall be provided at both ends of the cable and installed on the cable jacket within ten inches of the termination at the BDF/IDF and within 2 inches of the faceplate end.

Identifier Assignment

Apply the following criteria to assign identifiers to the components of the telecommunications infrastructure.

Horizontal Cables

Currently Fresno State has specified Superior Essex Series 77 Category 6 CMR/CMP as the recognized plenum wire for all horizontal runs. The colors used per run are blue, yellow, and white for each station outlet. All placed cable needs to be identified at both ends with ROOM, FACEPLATE NUMBER, and JACK position. Example: 361.02A for each cable. Labels will be generated by a commercial labeling machine and WILL NOT be hand written. Label will be placed within ten inches of the termination at the BDF/IDF and within 2 inches of the faceplate end. Labeling will be done mechanically and the labeling font size will be minimum 24 point, (3/8").

Backbone Cables

Assign identifiers to each cable from a given telecom room using numbers starting with 1.1, 1.2 etc. Contact Technology Services for exact identifiers.

Patch Panel Labeling

Each used port of a modular patch panel shall be labeled with ROOM, FACEPLATE NUMBER, and JACK position. See below. Example 124C.02A for an individual cable. Technology Services WILL provide “Cut Sheets” for labeling and termination. Patch panel labeling will be done mechanically and the labeling font size will be 18 point, (3/16”). Patch panel ports 1-12 & 25-36 will terminate on switch ports 1-24 and patch panel ports 13-24 & 37-48 will terminate on switch ports 25-48.

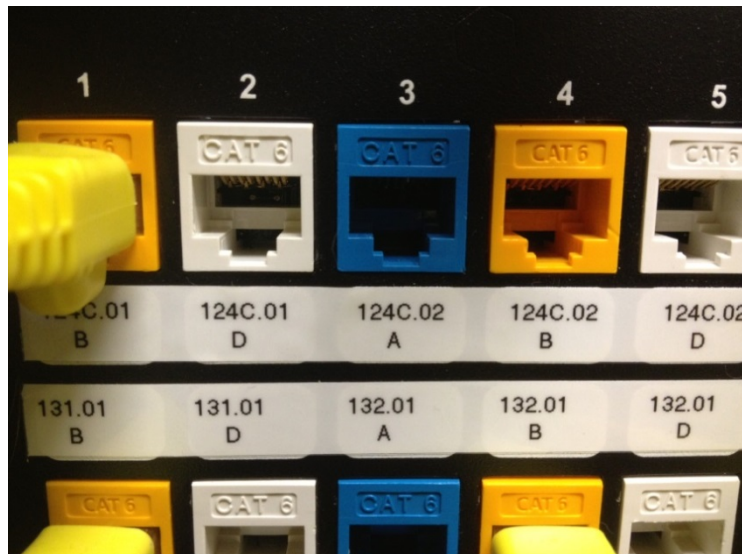

Example of “Cut Sheets” for labeling and termination from Technology Services based on above patch panel. All patch panel and switch and port locations are assigned by Technology Services and WILL NOT be altered unless approved IN ADVANCE by Technology Services.

BLDG	FLOOR	PHONE #	ROOM	JK #	P.P. #	PORT #	STACK	SWITCH	PORT	NOTES
015	1		124C	01B	1	1				
015	1		124C	01D	1	2				
015	1		124C	02A	1	3				
015	1		124C	02B	1	4				
015	1		124C	02D	1	5				
015	1		131	01B	1	25				
015	1		131	01D	1	26				
015	1		132	02A	1	27				
015	1		132	02B	1	28				
015	1		132	02D	1	29				

Outlet Labeling

Each faceplate shall be labeled with ROOM, FACEPLATE NUMBER, and JACK position. Example: 361.02A for each cable. Technology Services to provide “Cut Sheets” for labeling and termination.

8.10 Documentation Requirements

The Contractor must demonstrate successful completion of the following tasks for Technology Services to accept the telecommunications work:

1. Before executing any performance testing, the Contractor shall present a test plan to Technology Services for approval. Test equipment must have proof of calibration prior to the start of any testing. All testing will be done in accordance with (TIA) ANSI/TIA/EIA-568-B.1.
2. The Contractor has completed all testing and delivered copies of all test results to Technology Services. These records will be on a CD/DVD and on hardcopy.
3. All test results have been examined and approved by Technology Services. OSP and tie-cable copper test results cannot have more than a 1% failure rate and fiber optics and horizontal station cable test will have a zero percent failure rate.
4. Contractor will deliver "as built" drawings on CD/DVD and hardcopy and these documents will include conduit/cable locations, depth of any buried facilities, and measurement for the placement of conduits or underground facilities. Digital drawings will be delivered to Technology Services in an ACAD format (Rev 2012 or later).
5. Copies of all documentation required by this section have been delivered to Technology Services.
6. All punch list items are completed to the satisfaction of Technology Services.
7. Structured Cabling System Certification is provided to Technology Services.

Minor failures such as incomplete resolutions to punch list items shall be responded to at the discretion of Technology Services.

8.11 Construction Trailer Equipment

Construction Trailer voices and data services are the responsibility of the contractor, whether the contractor is invoiced by Plant Operations or Technology Services can be determined at the time of the project. Listed below are options for forms of payment, with initial installation costs either paid up front or amortized over the length of time that the trailer will be required to be on site.

This option also allows for as many data connections as there are telephone connections.

NOTE: These prices do not include any International charges, if used, these are billed separately

Trailer Size	Voice/Data Technology Services	Installation Cost	Monthly Cost	Amortized Cost*
Small	4 Phones 1 FAX	\$2300.00	\$125.00	\$315.00
Medium	9 Phones 1 FAX	\$4600.00	\$250.00	\$630.00
Large	14 Phones 1 FAX	\$6900.00	\$375.00	\$945.00

This example is for a contract that requires a Construction Trailer for 12 months

Trailer Size	Voice/Data Technology Services	Installation Cost	Monthly Cost	Amortized Cost*
Small	4 Phones 1 FAX	\$2300.00	\$125.00	\$220.00

Medium	9 Phones 1 FAX	\$4600.00	\$250.00	\$440.00
Large	14 Phones 1 FAX	\$6900.00	\$375.00	\$660.00

This example is for a contract that requires a Construction Trailer for 24 months

NOTE:*Amortized Cost= This eliminates the startup installation cost and allows installation cost to be paid on a monthly rate throughout the length of the time the trailer is on campus. Each case will be evaluated for unusual circumstances and may require additional fees.

9.0 WIRELESS LAN SERVICE

[See Technology Services for information](#)

10.0 INSTRUCTIONAL TECHNOLOGIES (CVS)

[See Technology Services for information](#)

INDEX on Next Page

Backboard	Camera, 48
Anchoring, 19	Data, 45
Fasteners, 19	Dual, 45
Fire Rating, 16	Energy Management Systems, 48
Location, 16	Labeling, 44, 45
Bonding	LCD Projector, 46
Conductor, 22	Numbering Scheme, 51
Pathways, 22	Power Meter, 49
Cable	Standard, 44
Backbone Labeling, 52	Television, 45, 47
Demolition, 14	Wall, 44
Horizontal Copper, 39	Wireless Access Points, 46
Horizontal Pathways(Station Cable), 29	Fiber
Link Description, 40	Backbone Cable, 35
Workstation Termination, 40	Backbone Capacity, 36
Cable Tray, 30	Connectors, 37
Access, 31	Failure Rate, 12, 54
Ballast Restrictions, 32	Indoor Backbone, 36
J Hooks, 33	Intrabuilding Capacity, 37
Mounting, 31	Labeling, 27
Primary Pathway, 32	SM Description, 36
Rated Hallway, 32	Splicing, 37
Retro Fit, 31	Split Duct, 27
Routing, 31	Testing Standards, 12
Secondary Pathway, 33	Type, 34
Support Method, 31	Validation, 12
Weight Capacity, 30	Grounding
Coaxial Station	Backbone, 22
Connectors, 43	Busbar, 22
Coaxial Station Cable	General, 21
General, 43	Installer
Construction, 18, 54	Certification, 10
New, 15, 16, 17, 33, 34	Labeling, 53
Renovation, 18, 33, 34	cut sheet, 53
Construction Trailer, 55	faceplate, 45
Copper	Faceplate, 46, 47, 49, 53
Failure Rates, 13	General, 52
Validation, 12	Location, 52
Cut Sheets	patch panel, 53
From TS, 53	Patch Panel, 52
Patch Panel, 53	size, 44, 45, 46, 48, 49, 52, 53
Documentation	Liquidated Damages
Standards, 10	Contract, 14
Faceplate, 51, 52	Delay in Completion, 14
Blackboard, 47, 48	General, 12, 13

Purchase Order, 14	Cooling, 20
National Electric Code	Doors, 16
50 Foot Limitation, 35	Environment, 20
OSP	Finishes, 16
Conduit Types, 24	Floor Loading, 18
Copper Splice Cases, 27	General, 11
Hand hole, 25	Grounding, 22
Home runs, 26	Location, 16
Innerduct, 26	Renovation, 17
Labeling, 26	Seismic Bracing, 18
Minimum Burial Depth, 26	Size, 15
Pathway, 26	Terminations, 40
Power Separation, 26	Types, 27
Split cover, 25	Unrelated Plumbing, 20
Split Duct, 27	UPS, 15, 23
Vault, 25	UPS Outlet, 23
Patch Panel, 37, 52, 58	UPS Power Strips, 23
Pathway	UPS Requirements, 29
Backbone, 29	Testing
Primary, 29	Backbone Fiber Optic Cabling, 37
PLUMBING, 20	Backbone Twisted Pair Cabling, 39
Power Meters, 42	Cat 6 Certification, 42
RJ45 jack, 44, 45	Cat6 Requirements, 40
SC connectors, 37	Completion Deadline, 12
Standard Faceplate, 51	Documentation, 53
Station Cable	Repair Rates, 13
General, 42	Work Area
Outlet Requirements, 50	Admin Areas, 51
Station Cables	Classroom, 41
Cat 6 Certification, 42	Computer Lab, 41
Color Designations, 42	Conference Room, 41, 51
Description, 52	Fixed Office, 41
Maximum Length, 42	Labs, 51
Subcontractors, 10	Large Classroom, 51
Telecom Room	Open Office, 41
120 Volt Outlets, 23	Public Area, 51
Air Changes, 21	Small Classroom, 51
Anchoring, 18	Special Use, 52
Ceiling, 16	Telecom Room, 41

APPROVED MATERIALS LIST

See separate list on Website

ADDENDUM 2.

TELECOMMUNICATIONS LEGEND (NO OTHERS WILL BE ACCEPTED)

FRESNO STATE STANDARD TELECOMMUNICATIONS SYMBOL LEGEND

SYMBOL LEGEND	
	WALL-EXISTING TELECOM OUTLET
	WALL-VOICE/DATA JACK
	WALL-DATA JACK
	WALL-DATA JACK 4
	WALL-DATA JACK 6
	WALL-FIBER DATA JACK
	WALL-VIDEO JACK
	WALL TELEPHONE OUTLET
	WALL-WIRELESS ACCESS POINT
	CEILING MOUNT-VOICE/DATA
	CEILING MOUNT-DATA
	CEILING MOUNT-WIRELESS ACCESS PT
	FLOOR MOUNT-VOICE/DATA
	FLOOR MOUNT-DATA
	FLOOR MOUNT-DATA 4
	FLOOR MOUNT-DATA 6
	FLOOR MOUNT-FIBER/DATA
	FLOOR MOUNT-VIDEO JACK
	WIREMOLD WITH DEVICES AS INDICATED
	CABLE TRAY
	CONDUIT
	UNDERGROUND CONDUIT
	J-HOOKS

	TELECOMMUNICATIONS WALL OUTLET – TYPICAL EXISTING OUTLET WITH NO CABLE – PREWIRE LOCATION ONLY
	TELECOMMUNICATIONS WALL OUTLET – TYPICAL VOICE/DATA JACK 1 VOICE CABLE AND 2 DATA CABLES
	TELECOMMUNICATIONS WALL OUTLET – TYPICAL DATA ONLY JACK 2 DATA CABLES
	TELECOMMUNICATIONS WALL OUTLET – TYPICAL DATA ONLY JACK 4 DATA CABLES
	TELECOMMUNICATIONS WALL OUTLET – TYPICAL DATA ONLY JACK 6 DATA CABLES
	TELECOMMUNICATIONS WALL OUTLET – TYPICAL DATA/FIBER JACK 1 DATA CABLES AND ONE FIBER CABLE (see drawing notes)
	TELECOMMUNICATIONS WALL OUTLET – TYPICAL VIDEO ONLY JACK 1 RG6 (OR EQUIVALENT) COAXIAL CABLE
	TELECOMMUNICATIONS WALL OUTLET – TYPICAL WALL PHONE JACK 48" ABOVE FINISHED FLOOR – 1 VOICE CABLE AND 1 DATA CABLE
	TELECOMMUNICATIONS WALL OUTLET – TYPICAL WIRELESS ACCESS POINT 2 DATA CABLES (see drawing notes for location)
	TELECOMMUNICATIONS CEILING OUTLET – TYPICAL VOICE/DATA JACK 1 VOICE CABLE AND 2 DATA CABLES
	TELECOMMUNICATIONS CEILING OUTLET – TYPICAL DATA ONLY JACK 2 DATA CABLES
	TELECOMMUNICATIONS CEILING OUTLET – TYPICAL WIRELESS ACCESS POINT 2 DATA CABLES (see drawing notes for location)
	TELECOMMUNICATIONS FLOOR OUTLET – TYPICAL VOICE/DATA JACK 1 VOICE CABLE AND 2 DATA CABLES
	TELECOMMUNICATIONS FLOOR OUTLET – TYPICAL DATA ONLY JACK 2 DATA CABLES
	TELECOMMUNICATIONS FLOOR OUTLET – TYPICAL DATA ONLY JACK 4 DATA CABLES
	TELECOMMUNICATIONS FLOOR OUTLET – TYPICAL DATA ONLY JACK 6 DATA CABLES
	TELECOMMUNICATIONS FLOOR OUTLET – TYPICAL DATA/FIBER JACK 1 DATA CABLES AND ONE FIBER CABLE (see drawing notes)
	TELECOMMUNICATIONS FLOOR OUTLET – TYPICAL VIDEO ONLY JACK 1 RG6 (OR EQUIVALENT) COAXIAL CABLE
	TELECOMMUNICATIONS WIREMOLD OUTLET – TYPICAL VOICE/DATA JACK 1 VOICE CABLE AND 2 DATA CABLES – LOCATION AS INDICATED
	TELECOMMUNICATIONS CABLE TRAY – SEE FRESNO STATE TELECOMMUNICATIONS STANDARDS FOR CABLE TRAY SPECIFICATIONS
	TELECOMMUNICATIONS CONDUIT – ALL CONDUIT WILL BE 1.25" EMT 1 RG6 (OR EQUIVALENT) COAXIAL CABLE
	TELECOMMUNICATIONS UNDERGROUND CONDUIT – SEE FRESNO STATE TELECOMMUNICATIONS STANDARDS FOR ADDITIONAL DETAILS
	TELECOMMUNICATIONS J-HOOK LOCATIONS – SEE FRESNO STATE TELECOMMUNICATIONS STANDARDS FOR ADDITIONAL DETAILS

.....End of Document.....